

ДОКУМЕНТ 1.1

С

A handwritten signature in black ink, consisting of several connected loops and a long horizontal stroke at the end.A handwritten signature in black ink, appearing as a stylized, cursive letter 'A' or similar character.

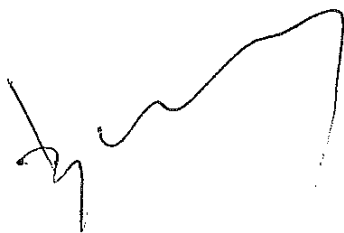

SIEMENS

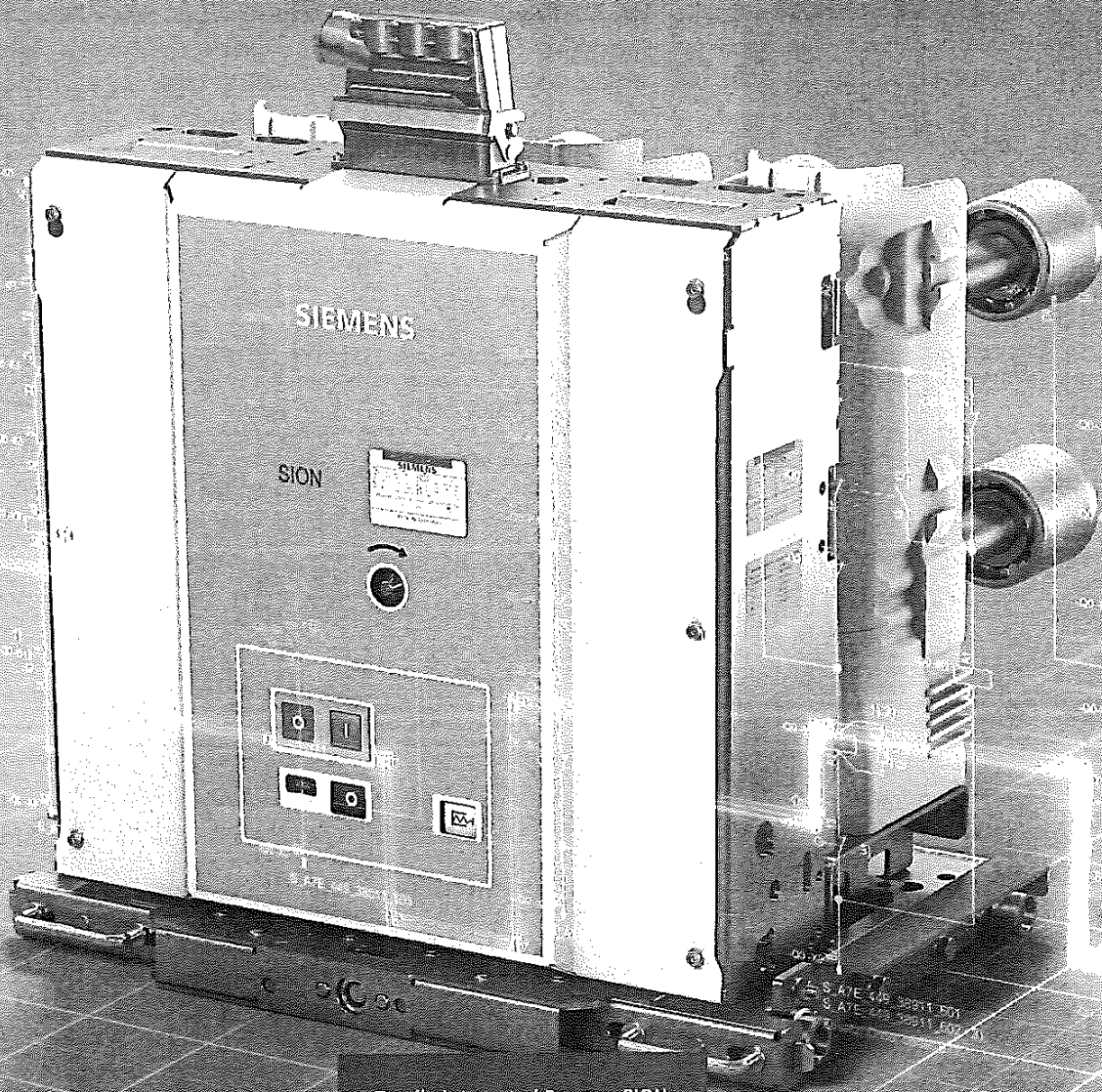

Totally Integrated Power – SION

SION Vacuum Circuit Breakers 3AE5 and 3AE1

Medium Voltage Equipment

Catalog
HG 11.02

Edition
2018

siemens.com/SION

000011



SION Vacuum Circuit Breakers 3AE5 and 3AE1

Medium-Voltage Equipment
Catalog HG 11.02 · 2018



Supersedes:
Catalog HG 11.02 · 2017

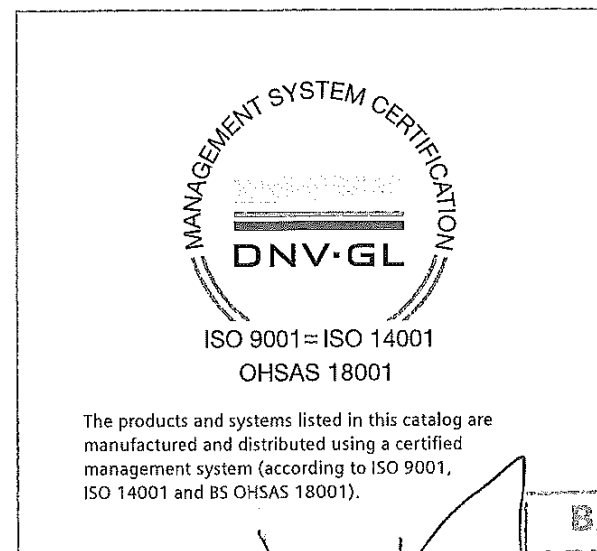

Contents	Page
Description	5
General information	6
Construction and mode of operation	8
Standards, maintenance-free design and interlocking	11
Ambient conditions, current carrying capacity and dielectric strength	12
Basic equipment, product range overview	13
Device selection	15
Article number structure	16
Configuration example	17
Circuit breaker and equipment package	18
Secondary equipment	30
Additional equipment	37
Accessories and spare parts	39
Technical data	49
Electrical data, dimensions and masses	50
Dimension drawings	66
Operating times and internal times, short-circuit protection of motors	74
Consumption data of releases	75
Circuit diagrams	76
Annex	79
Inquiry form	80
Configuration instructions	81
Configuration aid	Foldout page



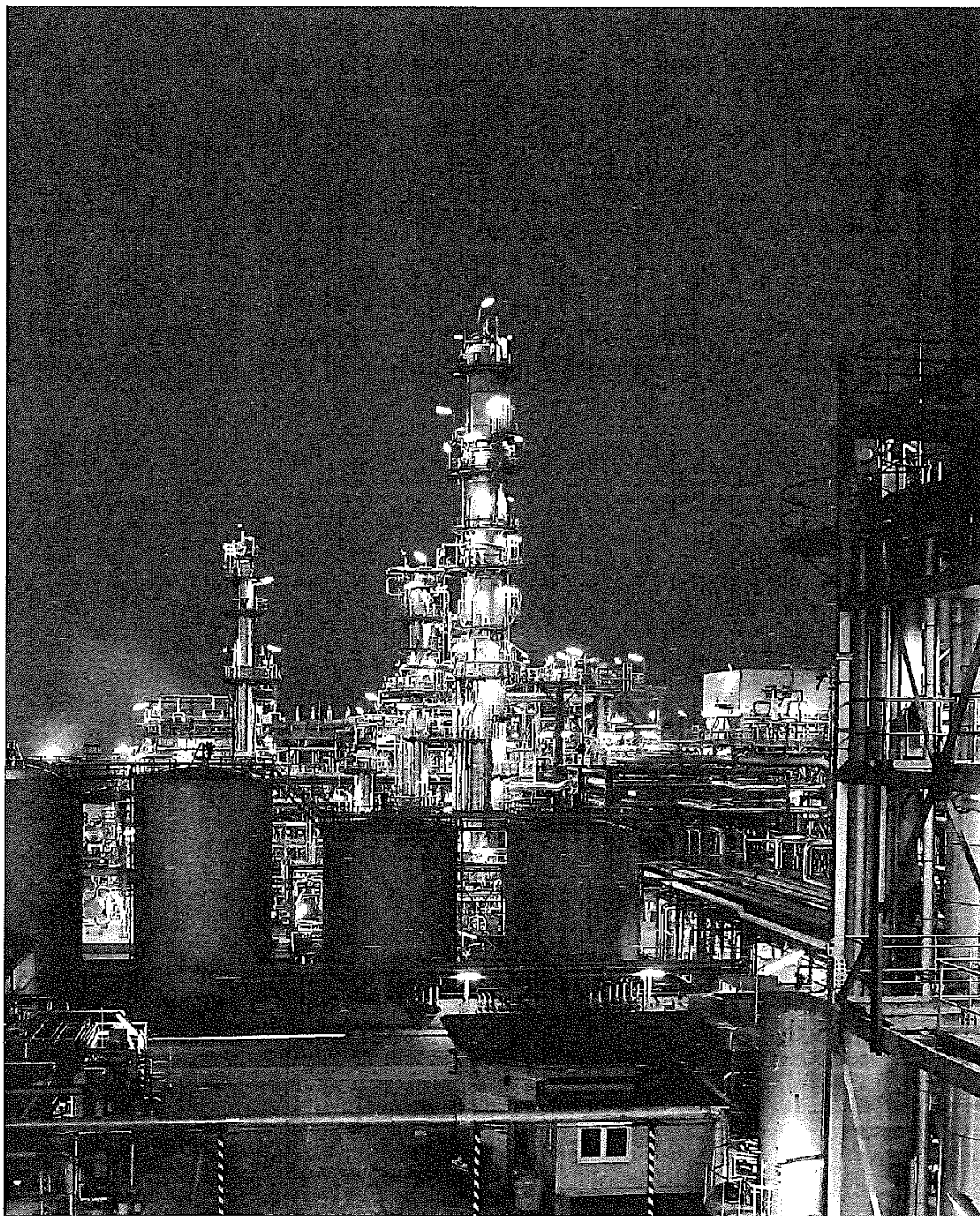



Industrial application: Refinery

Contents	Page
Description	5
General information	6
Construction and mode of operation	
Switching medium	8
Pole assemblies	8
Operating mechanism	8
Trip-free mechanism	8
Releases	9
Closing and anti-pumping	9
Closing spring charged indication	9
Circuit breaker tripping signal	9
Interlocking	9
Low-voltage interface	9
Withdrawable module	10
Withdrawable module with make-proof earthing switch	10
Standards	11
Maintenance-free design	11
Interlocking	11
Ambient and environmental conditions	
Ambient conditions	12
Current carrying capacity	12
Dielectric strength	12
Basic equipment	13
Product range overview	13

1

SM

BL

ВЕРНО С
ОРИГИНАЛА

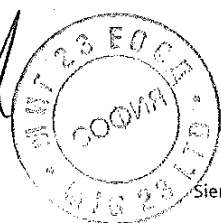

Signature

Description

General information

SION Vacuum Circuit Breaker 3AE5 and 3AE1 from 7.2 kV to 24 kV – The Modular Devices

1

SION vacuum circuit breakers control all switching operations in medium-voltage distribution systems and are suitable for installation in all established and new air-insulated medium-voltage switchgear as well as for retrofitting existing switchgear.

They are used for operation, for example, of overhead lines, cables, transformers, capacitors and motors.

The optional installation accessories enable easy integration into switchgear panels, and, maximally equipped as a withdrawable module with an earthing switch, form almost the complete circuit breaker compartment inside the switchgear.

Our comprehensive range of circuit breakers offers a wide selection of pole-center distances and widths across flats as well as various equipment options for voltage levels from 7.2 kV to 24 kV. The withdrawable part, contact arms, contacts and bushings enable easy integration in all customary medium-voltage switchgear types. Identical dimensions and connection dimensions across several voltage levels reduce planning costs and the variety of panel versions. High reliability and availability are a matter of course, as are 10,000 maintenance-free operating cycles.

SION vacuum circuit breaker for fixed mounting

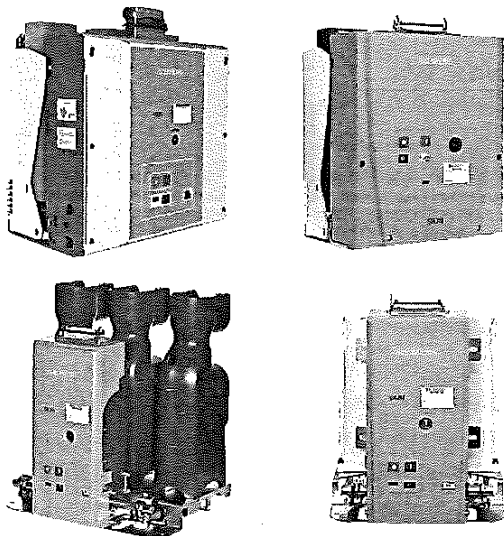

Thanks to a range of equipment options, SION vacuum circuit breakers can be precisely tailored to your requirements. This switching device can be mounted on a withdrawable part. Furthermore, mountable contact arms, contacts and bushings allow easy integration in your switchgear.

SION vacuum circuit breaker on withdrawable part

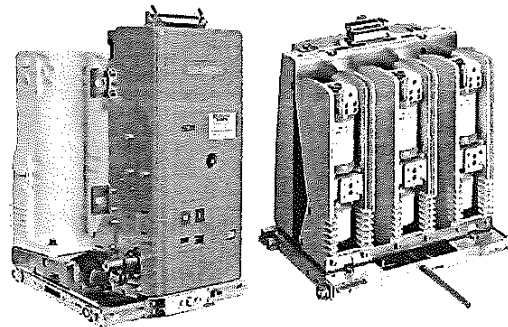

R-HG11-385-01

R-HG11-385-01

The circuit breaker mounted on a withdrawable part can be supplied both with and without contact arms and contacts.

SION vacuum circuit breaker on withdrawable part – with contacts

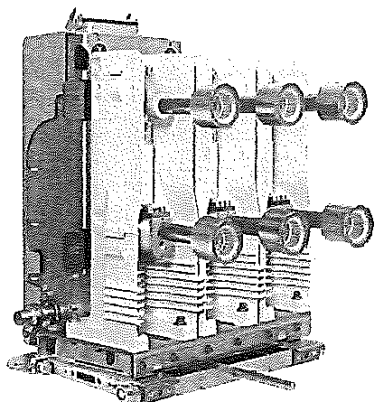

Withdrawable module with 3AE5 vacuum circuit breaker

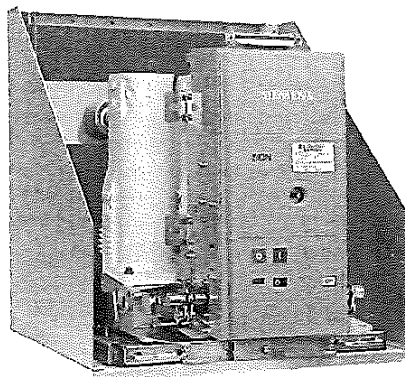

1

The SION vacuum circuit breakers can be supplied with contact arms and contacts.

The withdrawable module contains all components required for the circuit breaker compartment of a switchgear panel. It consists of the circuit breaker mounted on a withdrawable part, with contact arms, fitted in a cartridge with side and rear walls. The withdrawable module is equipped with bushings, fixed contacts, shutters and the shutter mechanism. The side and rear walls form the tested connection compartment.

Withdrawable module with earthing switch

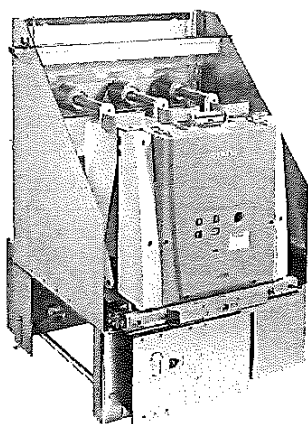

The withdrawable module is also available with an earthing switch. It contains all components required for the circuit breaker compartment of a switchgear panel. It consists of the circuit breaker mounted on a withdrawable part, with contact arms, fitted in a cartridge with side and rear walls. The withdrawable module is equipped with bushings, fixed contacts, shutters and the shutter mechanism, as well as with a make-proof earthing switch. The side and rear walls form the tested connection compartment.

ВЯРНО С
ОРИГИНАЛА

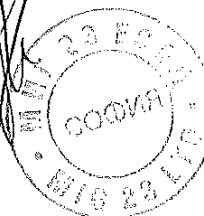

Description

Construction and mode of operation

1

Switching medium

Proven and fully developed for more than 40 years, vacuum switching technology is the principal arc-quenching element used in vacuum interrupters.

Pole assemblies

The pole assemblies consist of vacuum interrupters and pole shells. The vacuum interrupters are air-insulated and freely accessible. The pole assemblies are fixed on the mechanism mounting plate and supported by means of the pole shell (6). The vacuum interrupter (5) is mounted rigidly to the upper interrupter support. The lower part of the interrupter is guided into the lower interrupter support, allowing axial movement. The pole shell (6) absorbs external forces resulting from switching operations and the contact pressure.

Operating mechanism

The whole operating mechanism with motor (13), releases (11), indicators and actuating devices is mounted on the mechanism mounting plate (9). This compact design enables very fast operating times.

The circuit breaker operating mechanism is a stored-energy spring mechanism. The force is transmitted from the operating mechanism to the pole assemblies via operating levers. The closing spring (15) can be charged either electrically or manually, and latches in automatically when charging is complete. The closing spring (15) acts as a stored-energy mechanism.

To close the breaker, the closing spring (15) can be unlatched either mechanically at the device (ON pushbutton), or electrically by remote control. The closing spring (15) charges the opening and/or contact-pressure springs (17) as the breaker closes. The now discharged closing spring (15) will be charged again automatically by the motor (13).

In this way, the stored-energy mechanism stores the OPEN – CLOSE – OPEN operating sequence that is required for an auto-reclosing operation on the system side. All stored-energy mechanisms perform the switching duties of synchronizing, rapid load transfer, and auto-reclosing.

Trip-free mechanism

The circuit breakers have a trip-free mechanism. In the event of an opening command being given after a closing operation has been initiated, the moving contacts return to the open position and remain there even if the closing command is sustained. However, the vacuum circuit breaker contacts are momentarily in the closed position.

For charging the closing spring (15), the motor (13) operates in short-time duty. Therefore the voltage and power consumption might differ from the data of the motor rating plate.

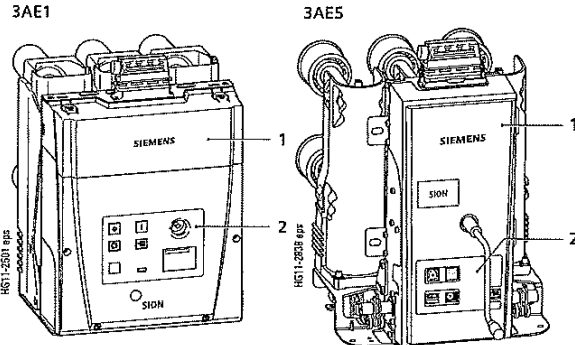

Front view

1 Cover of low-voltage interface

2 Central control board

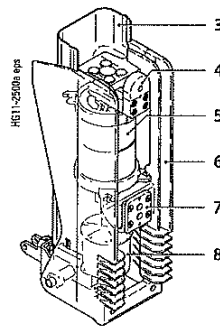

Pole structure

- 3 Insulating shell to the operating mechanism
- 4 Upper connection
- 5 Vacuum interrupter
- 6 Pole shell
- 7 Lower connection
- 8 Insulator

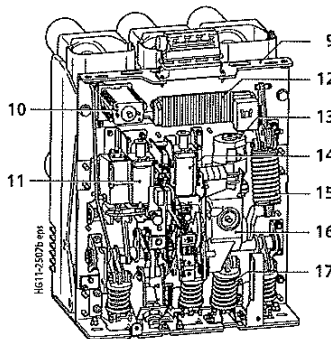

Operating mechanism 3AE1 without cover

- 9 Mechanism mounting plate
- 10 Auxiliary switch
- 11 1st release
- 12 Terminal strip
- 13 Motor
- 14 Closing solenoid
- 15 Closing spring
- 16 Gear
- 17 Opening spring

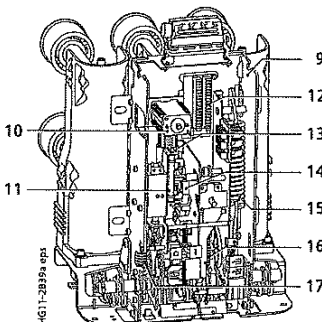

Operating mechanism 3AE5 without cover

- 9 Mechanism mounting plate
- 10 Auxiliary switch
- 11 1st release
- 12 Terminal strip
- 13 Motor
- 14 Closing solenoid
- 15 Closing spring
- 16 Gear
- 17 Opening spring

Releases

A release is a device that transfers electrical commands from an external source, such as a control room, to the latching mechanism of the vacuum circuit breaker so that it can be opened or closed. The releases are designed for short-time duty up to 1 minute and are reset internally.

The various types of releases available are described in detail below:

Closing solenoid

The closing solenoid unlatches the charged closing spring of the vacuum circuit breaker, closing it by electrical means.

Shunt releases

Shunt releases are used for automatic tripping of the circuit breaker by suitable protection relays and for deliberate tripping by electrical means. They are intended for connection to an external power supply (DC or AC voltage).

Current-transformer-operated releases

Current-transformer-operated releases consist of a stored energy mechanism, an unlatching mechanism and an electromagnet system. They are used when there is no external source of auxiliary power (e.g. a battery). Tripping is effected by means of a protection relay (e.g. overcurrent time protection) acting on the current-transformer-operated release.

Undervoltage releases

Undervoltage releases consist of a stored-energy mechanism, an unlatching mechanism and an electromagnet system that is permanently connected to the secondary or auxiliary voltage while the circuit breaker is closed. If the voltage falls below a predetermined value, unlatching of the release is enabled and the circuit breaker is opened via the stored-energy mechanism.

A maximum of two releases can be fitted as described on page 36. The consumption data of the releases is listed on page 87/88.

Closing and anti-pumping

In the standard version, the circuit breakers can be closed electrically via remote. In addition, they can be mechanically closed locally by direct unlatching of the closing spring. If constant electrical signals for CLOSE and OPEN commands are present at the circuit breaker at the same time, the circuit breaker will carry out an OPEN-CLOSE-OPEN or a CLOSE-OPEN operating sequence. A new CLOSE command is given only following a brief interruption of the closing signal. This prevents continuous closing and opening (= "pumping") operations.

Closing spring charged indication

The circuit breakers have a mechanically operated spring charged indicator. The charging status of the closing spring can also be queried electrically by means of an integrated position switch.

Circuit breaker tripping signal

During electrical opening, the NO contact S6 makes brief contact. This is often used to operate a hazard warning system which should respond to automatic tripping of the circuit breaker. In case of local control, the NO contact S6 does not close.

The corresponding circuit diagrams can be found in the associated circuit manuals. See also page 76.

InterlockingMechanical interlocking

At the interface of the mechanical interlocking of the circuit breaker, sensors on the switchgear side can check the switch position and prevent the associated disconnecter from being operated while the circuit breaker is closed. The system also prevents the circuit breaker from being closed while the associated disconnecter is in the fault position.

Circuit breakers mounted on withdrawable parts are mechanically interlocked so that the handle for racking the withdrawable part can only be inserted while the breaker is in the OPEN position. The lock of the withdrawable part can be released by operating the pushing handles and only while the withdrawable part is in the disconnected position.

If the circuit breaker on the withdrawable part is in an intermediate position (neither in the service nor in the disconnected position), operation is prevented by the mechanical interlocking.

An optional key-operated interlock enables mechanical closing only in combination with the operated lock.

Electrical interlocking

The auxiliary and signaling contacts which query the switch position of the circuit breaker or the position of the withdrawable part can be integrated in the switchgear interlocking concept. Furthermore, mechanical closing can also be prevented by means of an optional, electrical closing lock-out, in order to prevent impermissible switching sequences.

Low-voltage interface

The removable cover of the SION 3AE1 and 3AE5 vacuum circuit breakers enables easy access to the low-voltage interface. All customer-side control and signaling options are concentrated here.

1

ВЪРНО С
ОРИГИНАЛА

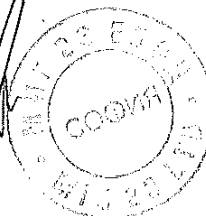

Description

Construction and mode of operation

1

Withdrawable module

The withdrawable module contains all components required for the circuit breaker compartment of a switchgear panel. It consists of the circuit breaker mounted on a withdrawable part, with contact arms, fitted in a cartridge with side and rear walls. The withdrawable module is equipped with bushings, fixed contacts, shutters and the shutter mechanism. The side and rear walls form the tested connection compartment.

The circuit breaker on the withdrawable part is racked into the cartridge with the handle by rotating the spindle. The shutter mechanism is controlled by lateral gates, and the shutters are opened for contacting. Signals for the service and disconnected positions are transmitted to the module connector at the low-voltage interface of the vacuum circuit breaker via the position switches of the withdrawable part.

Withdrawable module 3AE1

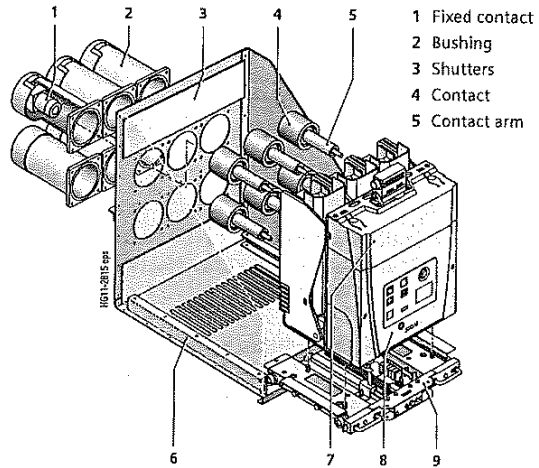

Withdrawable module with make-proof earthing switch

The make-proof earthing switch at the cartridge has a defined making capacity up to the values stated on the circuit breaker rating plate. It features a compact design with spring-operated mechanism and a switching angle of 90°, low torques for closing and opening, as well as low maintenance.

The make-proof earthing switch has been tested in the withdrawable module and complies with the relevant standards for the switchgear panels.

Withdrawable module 3AE5

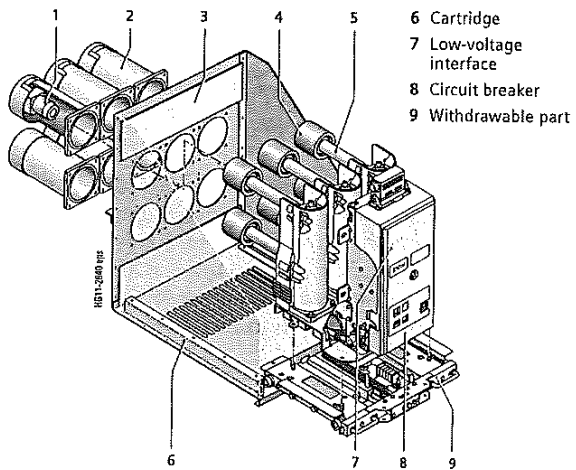

Standards

The circuit breakers conform to the following standards:

- IEC 62271-1
- IEC 62271-100

All circuit breakers fulfill the endurance classes

C2, E2, M2 and S1 according to IEC 62271-100, as well as the shortest rated operating sequence O - 0.3s - CO - 15s - CO.

3AE5 circuit breakers up to 12 kV / 31.5 kA / 1250 A comply with the DNVGL-CG-0339 classification for marine applications.

The withdrawable modules have been tested according to

- IEC 62271-200, 62271-1 and 62271-102 regarding
 - Dielectric strength
 - Temperature rise
 - Switching capacity.



For class C2, all circuit breakers comply with the following values acc. to IEC 62271-100.

Rated voltage	Line	Cable	Capacitors	Back-to-back capacitor bank	
	Rated line-charging breaking current	Rated cable-charging breaking current	Rated single-capacitor-bank breaking current	Rated back-to-back-capacitor-bank breaking current	Frequency of the inrush making current
U_i kV, r.m.s.	I_l A, r.m.s.	I_c A, r.m.s.	I_{cb} A, r.m.s.	I_{bb} A, r.m.s.	f_{in} Hz
7.2	10	10	400	400	4250
12	10	25	400	400	4250
17.5	10	31.5	400	400	4250
24	10	31.5	400	400	4250

Rated back-to-back-capacitor-bank inrush making current – see chapter 3: Technical data

Maintenance-free design

The circuit breakers are maintenance-free:

- Under normal ambient conditions according to IEC 62271-1
- Up to 10,000 operating cycles maintenance-free
 - no regreasing
 - no readjusting
- Up to 30,000 operating cycles with maintenance work for the 3AE5

The ratings are independent within their tolerances of the switching frequency or standing times without switching.

Interlocking

Vacuum circuit breaker	Disconnected position	Racking	Service position	Switching state of vacuum circuit breaker	Interlocking of vacuum circuit breaker against closing (optionally with key-operated interlock)	Interlocking of withdrawable part in the switchgear panel (latching of locking handles) in disconnected position	Interlocking of racking of the withdrawable part (between disconnected, test and service position)	Switching state of the earthing switch	Interlocking of the earthing switch against closing
Fixed-mounted			■ OPEN ■ CLOSED		Interlockable				
Disconnecting on withdrawable part and in withdrawable module	■			CLOSED OPEN OPEN CLOSED				Active	
Disconnecting on withdrawable part, in withdrawable module and with earthing switch	■	■		CLOSED OPEN OPEN CLOSED	Active	Active Active	Active	OPEN OPEN OPEN OPEN	Active Active
Grounding on withdrawable part, in withdrawable module and with earthing switch	■			OPEN or CLOSED OPEN or CLOSED		Active		OPEN OPEN	

Handwritten signature

Handwritten signature

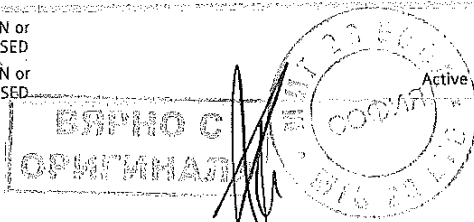

Description

Ambient conditions, current carrying capacity and dielectric strength

SION Vacuum Circuit Breakers 3AE5 and 3AE1

1

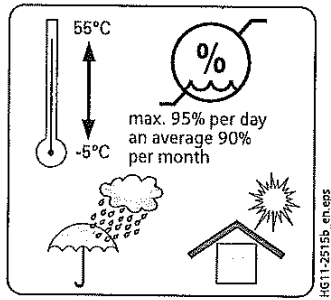

Ambient conditions

The circuit breakers are designed for normal operating conditions as defined in IEC 62271-100. Condensation can occasionally occur under the ambient conditions shown opposite.

The circuit breakers are suitable for use in the following climatic classes according to IEC 60721, Part 3-3:

Climatic ambient conditions:	Class 3K4 ¹⁾
Biological ambient conditions:	Class 3B1
Mechanical ambient conditions:	Class 3M2
Chemically-active substances:	Class 3CS ³⁾
Mechanically-active substances:	Class 3S2 ²⁾

- 1) Lower temperature limit: -5 °C (with order code A40 down to -25 °C)
- 2) Restriction: Clean insulation parts
- 3) Without appearance of saline fog and simultaneous condensation

Current carrying capacity

The rated normal currents specified in the diagram have been defined according to IEC 62271-100 for an ambient air temperature of +40 °C and apply to open switchgear.

For enclosed switchgear, the data of the switchgear manufacturer applies.

At ambient air temperatures below +40 °C, higher normal currents can be carried (see diagram):

- Characteristics curve 1 = Rated normal current 800 A
- Characteristics curve 2 = Rated normal current 1250 A
- Characteristics curve 3 = Rated normal current 1600 A
- Characteristics curve 4 = Rated normal current 2000 A
- Characteristics curve 5 = Rated normal current 2500 A
- Characteristics curve 6 = Rated normal current 3150 A

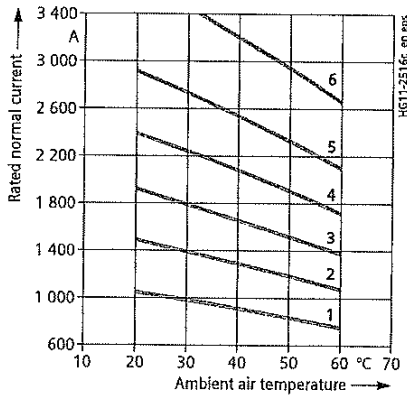

Dielectric strength

The dielectric strength of air insulation decreases with increasing altitude due to lower air density. According to IEC 62271-1, the rated lightning impulse withstand voltage and the rated short-duration power-frequency withstand voltage specified in chapter "Technical data" apply to a site altitude of 1000 m above sea level. For altitudes above 1000 m, the insulation level must be corrected according to the diagram shown opposite.

The characteristics curve shown applies to both rated withstand voltages.

When selecting the devices, the following applies:

- $U \geq U_0 \times K_a$
- U Rated withstand voltage under reference atmosphere
- U_0 Rated withstand voltage requested for the installation location
- K_a Altitude correction factor according to the diagram shown opposite

Example

For a requested rated lightning impulse voltage of 75 kV at an altitude of 2500 m, an insulation level of at least 90 kV under reference atmosphere is required:

$$90 \text{ kV} \geq 75 \text{ kV} \times 1.2$$

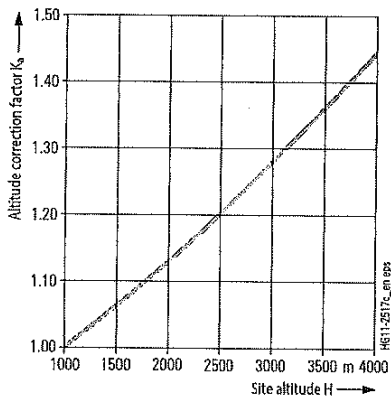

Equipment

Features	Minimum equipment	Alternative equipment	Remarks
Operating mechanism	Electrical operating mechanism	None	Also for manual operation
Closing	Closing solenoid and mechanical manual closing	None	-
1st release	Shunt release	Undervoltage release, c.t.-operated release	For SION 3AE5, only shunt releases are possible
2nd release	None	Shunt release, undervoltage release, c.t.-operated release	Combination of 2 undervoltage releases or 2 c.t.-operated releases is not possible for 3AE1
3rd release	None	Shunt release, c.t.-operated release	Only in combination with wide operating mechanism housing; combination of 2 undervoltage releases is not possible for 3AE5.
Varistor circuit	Standard for ≥ 60 V DC	None	For limiting switching overvoltages
Auxiliary switch	6 NO + 6 NC	12 NO + 12 NC	-
Plug connection	27-pole terminal strip f. SION 3AE1 20-pole plug connector f. SION 3AE5	24-pole plug, 64-pole plug	12 NO + 12 NC not available with 24-pole plug
Anti-pumping	Available	None	-
Circuit breaker tripping signal	None	Possible	-
Operation cycles counter	Available	None	-
Position switches for withdrawable part	5 momentary-contact position switches per position	None	-
Interlocking	Mechanical interlocking available at the withdrawable module	Mechanical interlocking for circuit breaker Electrical closing lock-out for 3AE5 Key-operated interlocking	Required for withdrawable part
Installation type	Fixed-mounted	Withdrawable part with/without contact arms and contact, fixed contacts and bushings, withdrawable module with/without make-proof earthing switch	-



Product range overview: Circuit breaker without installation accessories

Type	Rated voltage kV	Rated short-circuit breaking current kA	Rated normal current A	Pole-center distance (in mm)									
				150				160					
				Width across flats (in mm)									
205	275	310	205	275	310	205	275	310	310				
3AE50	7.2	16/20/25/31.5	800/1250	■	■	■	■	■	■	■	■	■	■
3AE50	7.2	16/20/25/31.5	1600										■
3AE50	7.2	25/31.5	2000/2500										■
3AE10	7.2	40	1250/2000 2500/3150										■
3AE51	12	16/20/25/31.5	800/1250	■	■	■	■	■	■	■	■	■	■
3AE51	12	16/20/25/31.5	1600										■
3AE51	12	20/25/31.5	2000/2500										■
3AE11	12	40	1250/2000 2500/3150										■
3AE52	17.5	16/25/31.5	800/1250	■	■	■	■	■	■	■	■	■	■
3EA52	17.5	16/25/31.5	1600										■
3AE52	17.5	25/31.5	2000/2500										■
3AE12	17.5	40	1250/2000/ 2500/3150										■
3AE13/3AE53	24	16/20/25	800/1250										■
3AE13	24	16	800/1250/2000										■
		20/25	2000/2500										■

Note: The circuit breaker is available with various installation accessories. These versions can be configured from page 18 onwards.

Handwritten signature

Handwritten signature

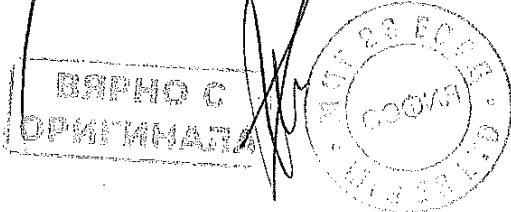

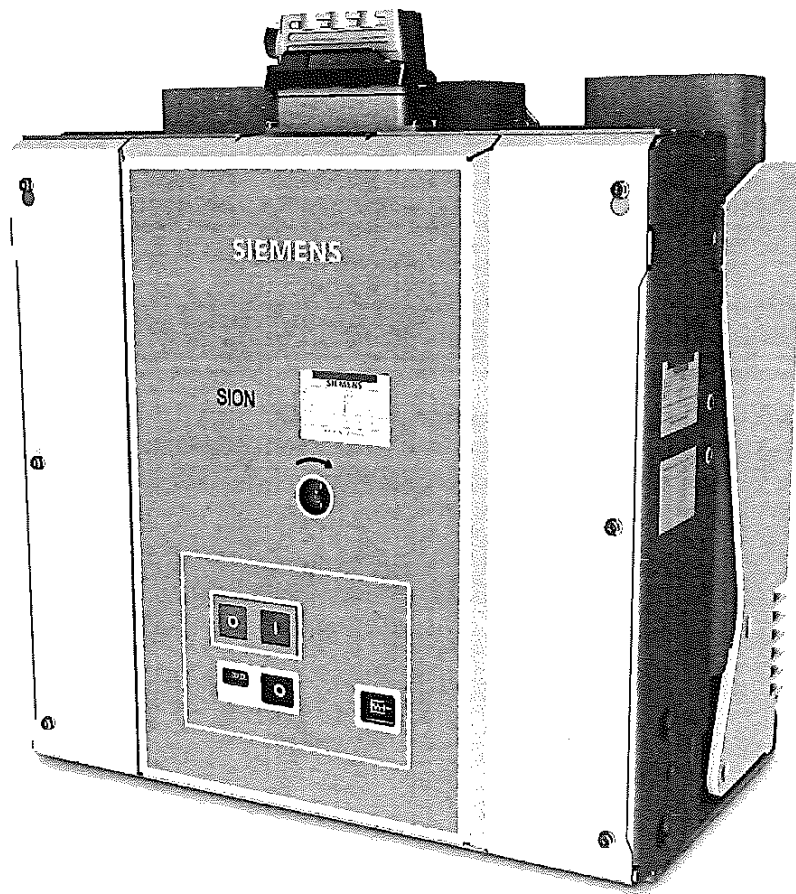



3AE5 vacuum circuit breaker as fixed-mounted version

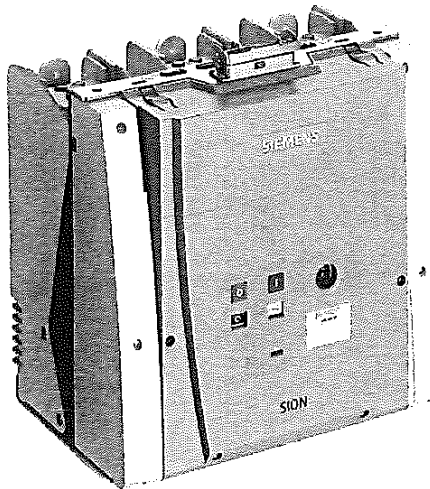

3AE1 vacuum circuit breaker as fixed-mounted version

Contents Page

Device selection 15

Article number structure 16
Configuration example 17

Circuit breaker and equipment package
Voltage level 7.2 kV 18
Voltage level 12 kV 21
Voltage level 17.5 kV 25
Voltage level 24 kV 28

Secondary equipment
Release combination 30
Operating voltage of the closing solenoid 31
Operating voltage of the 1st release 31
Operating voltage of the 2nd release 32
Circuit breaker installation accessories 33
Operating voltage of the drive motor 34
Interlocking, auxiliary switch, circuit breaker tripping signal and low-voltage interface 35
Languages of operating instructions and rating plate; AC frequency of operating voltages 36
Additional equipment 37

Accessories and spare parts
Rating plate 39
Accessories catalog 39

2

8-HG11-378.tif

8-HG11-176.eps

Handwritten signatures and stamps at the bottom of the page, including a circular stamp with Cyrillic text and the number 000018.

Device selection
Circuit breaker and equipment package

SION Vacuum Circuit Breakers 3AE5 and 3AE1

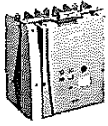

7.2 kV

Position: 1 2 3 4 5 6 7 - 8 9-12 13th position = Equipment package 14-16 Order codes

Rated voltage for 50/60 Hz U_n kV	Rated lightning impulse voltage U_p kV	Rated short-duration power-frequency withstand voltage U_s kV	Rated short-circuit breaking current with 36% DC component I_b kA	Rated short-circuit making current (at 50/60 Hz) I_m kA	Pole-center distance mm	Width across flats mm	Rated normal current I_n A	Article No.:	1	2	3	4	5	6	7	-	8	9-12	13th position = Equipment package	14-16	Order codes	
7.2	60	20	40	100/104	210	310	1250	3 A E 1	■	■	■	■	■	■	■	■	■	■	■	■	■	■
						310	2000	3 A E 1 0 8 6 - 4	■	■	■	■	■	■	■	■	■	■	■	■	■	■
						310	2500	3 A E 1 0 8 6 - 6	■	■	■	■	■	■	■	■	■	■	■	■	■	■
						310	3150	3 A E 1 0 8 6 - 7	■	■	■	■	■	■	■	■	■	■	■	■	■	■
Special version $U_d = 32$ kV																						

See pages 35 and 36

Orderable versions	1	2	3	4	5	6	7	8	9-12	13th position = Equipment package	14-16	Order codes
Circuit breaker for fixed mounting, without circuit breaker installation accessories	■	■	■	■	■	■	■	■	■	■	■	■
On withdrawable part	■	■	■	■	■	■	■	■	■	■	■	■
On withdrawable part with complete contact system *	■	■	■	■	■	■	■	■	■	■	■	■
On withdrawable part with complete contact system and bushings *	■	■	■	■	■	■	■	■	■	■	■	■
Withdrawable module without earthing switch	■	■	■	■	■	■	■	■	■	■	■	■
Withdrawable module with earthing switch	■	■	■	■	■	■	■	■	■	■	■	■

See pages 38 to 40

See page 41

- Z E 1 6

Legend: ● With contact system
■ Without contact system

*) Can also be ordered without withdrawable part, see page 37, 13th position

2

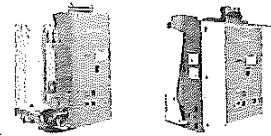

12 kV

Position: 1 2 3 4 5 6 7 - 8 9-12

13th position – Equipment package

14-16

Order codes

Article No.: 3 A E 5

Rated voltage for 50/60 Hz U_n (kV)	Rated lightning impulse voltage U_p (kV)	Rated short-duration power-frequency withstand voltage U_i (kV)	Rated short-circuit-breaking current with 50% DC component I_{sc} (kA)	Rated short-circuit-making current (at 50/60 Hz) I_m (kA)	Pole-center distance (mm)	Width across flats (mm)	Rated normal current I_n (A)								
12	75	28	31.5	80/82	310	2000	3 A E 5 5 8 5 - 4								
					310	2500	3 A E 5 5 8 5 - 6								
12	75	28	31.5	80/82	210	310	800 3 A E 5 1 8 5 - 1								
					310	1250	3 A E 5 1 8 5 - 2								
					310	1600	3 A E 5 1 8 5 - 3								
					310	2000	3 A E 5 1 8 5 - 4								
					310	2500	3 A E 5 1 8 5 - 6								
					275	800	3 A E 5 1 7 5 - 1								
					275	1250	3 A E 5 1 7 5 - 2								
					205	800	3 A E 5 1 6 5 - 1								
					205	1250	3 A E 5 1 6 5 - 2								
					160	310	800 3 A E 5 1 5 5 - 1								
					160	310	1250 3 A E 5 1 5 5 - 2								
					160	310	1600 3 A E 5 1 5 5 - 3								
					160	275	800 3 A E 5 1 4 5 - 1								
					160	275	1250 3 A E 5 1 4 5 - 2								
					160	205	800 3 A E 5 1 3 5 - 1								
					160	205	1250 3 A E 5 1 3 5 - 2								
					150	310	800 3 A E 5 1 2 5 - 1								
					150	310	1250 3 A E 5 1 2 5 - 2								
					150	310	1600 3 A E 5 1 2 5 - 3								
					150	275	800 3 A E 5 1 1 5 - 1								
					150	275	1250 3 A E 5 1 1 5 - 2								
					150	205	800 3 A E 5 1 0 5 - 1								
					150	205	1250 3 A E 5 1 0 5 - 2								
					150	205	1250 3 A E 5 1 0 5 - 2								

See pages 35 and 36

Orderable versions

Circuit breaker for fixed mounting, without circuit breaker installation accessories

On withdrawable part

On withdrawable part with complete contact system *

On withdrawable part with complete contact system and bushings *

Withdrawable module without earthing switch

Withdrawable module with earthing switch

See pages 38 to 40

See page 41



Special version $U_n = 42$ kV

$U_p = 95$ kV

Circuit breaker for installation in NXAIR World ¹⁾

12	75	28	25	63/65	160	275	800 3 A E 5 5 5 4 - 1	<input type="checkbox"/>							
					160	275	1250 3 A E 5 5 5 4 - 2	<input type="checkbox"/>							
					210	275	1600 3 A E 5 5 6 4 - 3	<input type="checkbox"/>							
			31.5	80/82	160	275	800 3 A E 5 5 5 5 - 1	<input type="checkbox"/>							
					160	275	1250 3 A E 5 5 5 5 - 2	<input type="checkbox"/>							
					210	275	1250 3 A E 5 5 6 5 - 2	<input type="checkbox"/>							
					210	275	1600 3 A E 5 5 6 5 - 3	<input type="checkbox"/>							
					210	275	2500 3 A E 5 5 6 5 - 6	<input type="checkbox"/>							

Special version $U_n = 42$ kV

$I_{sc}^{**}) = 26.3$ kA

$U_p = 95$ kV

- Z E 1 3
- Z E 9 5
- Z W 6 3
- Z W 6 3
- Z W 6 3
- Z W 6 3
- Z W 6 3
- Z W 6 3
- Z W 6 3
- Z W 6 3
- Z E 1 3
- Z E 4 6
- Z E 9 5

1) W63 is absolutely necessary as order code

Legend: ● With contact system
■ Without contact system

*) Can also be ordered without withdrawable part, see page 37, 13th position

**) Only possible with $I_{sc} = 25$ kA

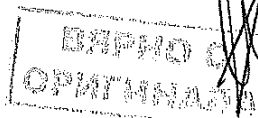

Device selection
Circuit breaker and equipment package

SION Vacuum Circuit Breakers 3AE5 and 3AE1

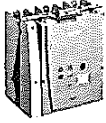

12 kV

2

Rated voltage for 50/60 Hz		Rated lightning impulse voltage		Rated short-duration power-frequency withstand voltage		Rated short-circuit breaking current with 36% DC component		Rated short-circuit making current (at 50/60 Hz)		Pole-center distance		Width across flats		Rated normal current		Position: 1 2 3 4 5 6 7 - 8 9-12 13th position = Equipment package 14-16												Order codes				
U_n	U_p	U_e	I_{sc}	I_{ms}	mm	mm	I_n	Article No.:												Orderable versions												
kV	kV	kV	kA	kA	mm	mm	A	3	A	E	1	5	8	6	-	2	See pages 35 and 36															
12	75	28	40	100/104	275	310	1250	3	A	E	1	5	8	6	-	2																
						310	2000	3	A	E	1	5	8	6	-	4																
						310	2500	3	A	E	1	5	8	6	-	6																
						310	3150	3	A	E	1	5	8	6	-	7																
					210	310	1250	3	A	E	1	1	8	6	-	2																
						310	2000	3	A	E	1	1	8	6	-	4																
						310	2500	3	A	E	1	1	8	6	-	6																
						310	3150	3	A	E	1	1	8	6	-	7																
Circuit breaker for installation in NXAIR World 1)																																
Special version $U_d = 42$ kV																																
				40	100/104	210	275	1250	3	A	E	1	5	6	6	-	2													- Z E 1 3		
							275	2500	3	A	E	1	5	6	6	-	6													- Z W 6 3		
							275	3150	3	A	E	1	5	6	6	-	7													- Z W 6 3		
Special version $U_d = 42$ kV																							- Z E 1 3									

1) W63 is absolutely necessary as order code

*) Can also be ordered without withdrawable part, see page 37, 13th position

Legend: ● With contact system
■ Without contact system

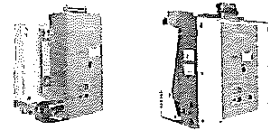

17.5 kV

Position: 1 2 3 4 5 6 7 - 8 9-12

13th position = Equipment package 14-16

Order codes

Article No.: 3 A E 5

Rated voltage for 50/60 Hz	Rated lightning impulse voltage	Rated short-duration power-frequency withstand voltage	Rated short-circuit breaking current with 50% DC component	Rated short-circuit making current (at 50/60 Hz)	Pole-center distance	Width across flats	Rated normal current	Position	Orderable versions
U_n (kV)	U_p (kV)	U_d (kV)	I_{cn} (kA)	I_m (kA)	(mm)	(mm)	I_n (A)		
17.5	95	38	16	40/42	210	310	800	3 A E 5 2 8 2 - 1	●
						310	1250	3 A E 5 2 8 2 - 2	●
						310	1600	3 A E 5 2 8 2 - 3	●
						275	800	3 A E 5 2 7 2 - 1	●
						275	1250	3 A E 5 2 7 2 - 2	●
						205	800	3 A E 5 2 6 2 - 1	●
						205	1250	3 A E 5 2 6 2 - 2	●
					160	310	800	3 A E 5 2 5 2 - 1	●
						310	1250	3 A E 5 2 5 2 - 2	●
						310	1600	3 A E 5 2 5 2 - 3	●
						275	800	3 A E 5 2 4 2 - 1	●
						275	1250	3 A E 5 2 4 2 - 2	●
						205	800	3 A E 5 2 3 2 - 1	●
						205	1250	3 A E 5 2 3 2 - 2	●
					150	310	800	3 A E 5 2 2 2 - 1	●
						310	1250	3 A E 5 2 2 2 - 2	●
						310	1600	3 A E 5 2 2 2 - 3	●
						275	800	3 A E 5 2 1 2 - 1	●
						275	1250	3 A E 5 2 1 2 - 2	●
						205	800	3 A E 5 2 0 2 - 1	●
						205	1250	3 A E 5 2 0 2 - 2	●
17.5	95	38	25	63/65	275	310	2000	3 A E 5 6 5 4 - 4	●
						310	2500	3 A E 5 6 5 4 - 6	●
					210	310	800	3 A E 5 2 8 4 - 1	●
						310	1250	3 A E 5 2 8 4 - 2	●
						310	1600	3 A E 5 2 8 4 - 3	●
						310	2000	3 A E 5 2 8 4 - 4	●
						310	2500	3 A E 5 2 8 4 - 6	●
						275	800	3 A E 5 2 7 4 - 1	●
						275	1250	3 A E 5 2 7 4 - 2	●
						205	800	3 A E 5 2 6 4 - 1	●
						205	1250	3 A E 5 2 6 4 - 2	●
					160	310	800	3 A E 5 2 5 4 - 1	●
						310	1250	3 A E 5 2 5 4 - 2	●
						310	1600	3 A E 5 2 5 4 - 3	●
						275	800	3 A E 5 2 4 4 - 1	●
						275	1250	3 A E 5 2 4 4 - 2	●
						205	800	3 A E 5 2 3 4 - 1	●
						205	1250	3 A E 5 2 3 4 - 2	●
					150	310	800	3 A E 5 2 2 4 - 1	●
						310	1250	3 A E 5 2 2 4 - 2	●
						310	1600	3 A E 5 2 2 4 - 3	●
						275	800	3 A E 5 2 1 4 - 1	●
						275	1250	3 A E 5 2 1 4 - 2	●
						205	800	3 A E 5 2 0 4 - 1	●
						205	1250	3 A E 5 2 0 4 - 2	●

See pages 35 and 36

- Circuit breaker for fixed mounting, without circuit breaker installation accessories
- On withdrawable part
- On withdrawable part with complete contact system *
- On withdrawable part with complete contact system and bushings *
- Withdrawable module without earthing switch
- Withdrawable module with earthing switch

See pages 38 to 40

See page 41

2

Legend: ● With contact system
■ Without contact system

* Can also be ordered without withdrawable part, see page 37, 13th position.
** As a difference, other insulating shells are also possible, see page 37

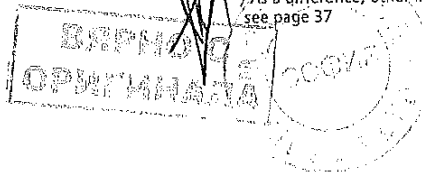

Device selection
Circuit breaker and equipment package

SION Vacuum Circuit Breakers 3AE5 and 3AE1

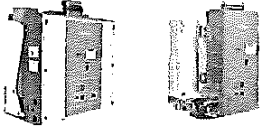

17.5 kV

Position: 1 2 3 4 5 6 7 8 9-12 13th position = Equipment package 14-16 Order codes

Article No.: 3 A E 5 6 5 5 - 2

Rated voltage for 50/60 Hz U_n KV	Rated lightning impulse voltage U_p KV	Rated short-duration power-frequency withstand voltage U_d KV	Rated short-circuit breaking current with 50% DC component I_{br} KA	Rated short-circuit making current (at 50/60 Hz) I_{ma} KA	Pole-center distance mm	Width across flats mm	Rated normal current I_n A	Orderable versions																						
								1	2	3	4	5	6	7	8	9-12	13th position = Equipment package	14-16	Order codes											
17.5	95	38	31.5	63/65	275	310	1250	3	A	E	5	6	5	5	-	2	■	■	●	●	●	●	●	-	Z	D	9	0**		
						310	1600	3	A	E	5	6	5	5	-	3	■	■	●	●	●	●	●	●	-	Z	D	9	0**	
						310	2000	3	A	E	5	6	5	5	-	4	■	■	●	●	●	●	●	●	-	Z	D	9	0**	
						310	2500	3	A	E	5	6	5	5	-	6	■	■	●	●	●	●	●	●	-	Z	D	9	0**	
					210	310	800	3	A	E	5	2	8	5	-	1	■	■	●	●	●	●	●	●	-	Z	D	9	0**	
						310	1250	3	A	E	5	2	8	5	-	2	■	■	●	●	●	●	●	●	-	Z	D	9	0**	
						310	1600	3	A	E	5	2	8	5	-	3	■	■	●	●	●	●	●	●	-	Z	D	9	0**	
						310	2000	3	A	E	5	2	8	5	-	4	■	■	●	●	●	●	●	●	-	Z	D	9	0**	
						310	2500	3	A	E	5	2	8	5	-	6	■	■	●	●	●	●	●	●	-	Z	D	9	0**	
						275	800	3	A	E	5	2	7	5	-	1	■	■	●	●	●	●	●	●	-	Z	D	9	0**	
						275	1250	3	A	E	5	2	7	5	-	2	■	■	●	●	●	●	●	●	-	Z	D	9	0**	
						205	800	3	A	E	5	2	6	5	-	1	■	■	●	●	●	●	●	●	-	Z	D	9	0**	
						205	1250	3	A	E	5	2	6	5	-	2	■	■	●	●	●	●	●	●	-	Z	D	9	0**	
					160	310	800	3	A	E	5	2	5	5	-	1	■	■	●	●	●	●	●	●	-	Z	D	9	0**	
						310	1250	3	A	E	5	2	5	5	-	2	■	■	●	●	●	●	●	●	-	Z	D	9	0**	
						310	1600	3	A	E	5	2	5	5	-	3	■	■	●	●	●	●	●	●	-	Z	D	9	0**	
						275	800	3	A	E	5	2	4	5	-	1	■	■	●	●	●	●	●	●	-	Z	D	9	0**	
						275	1250	3	A	E	5	2	4	5	-	2	■	■	●	●	●	●	●	●	-	Z	D	9	0**	
						205	800	3	A	E	5	2	3	5	-	1	■	■	●	●	●	●	●	●	-	Z	D	9	0**	
						205	1250	3	A	E	5	2	3	5	-	2	■	■	●	●	●	●	●	●	-	Z	D	9	0**	
					150	310	800	3	A	E	5	2	2	5	-	1	■	■	●	●	●	●	●	●	-	Z	D	9	0**	
						310	1250	3	A	E	5	2	2	5	-	2	■	■	●	●	●	●	●	●	-	Z	D	9	0**	
						310	1600	3	A	E	5	2	2	5	-	3	■	■	●	●	●	●	●	●	-	Z	D	9	0**	
						275	800	3	A	E	5	2	1	5	-	1	■	■	●	●	●	●	●	●	-	Z	D	9	0**	
						275	1250	3	A	E	5	2	1	5	-	2	■	■	●	●	●	●	●	●	-	Z	D	9	0**	
						205	800	3	A	E	5	2	0	5	-	1	■	■	●	●	●	●	●	●	-	Z	D	9	0**	
						205	1250	3	A	E	5	2	0	5	-	2	■	■	●	●	●	●	●	●	-	Z	D	9	0**	
Circuit breaker for installation in NXAIR World 1)																														
17.5	95	38	25	63/65	160	275	800	3	A	E	5	6	2	4	-	1	■	■	●	●	●	●	●	●	-	Z	W	6	3	
						275	1250	3	A	E	5	6	2	4	-	2	■	■	●	●	●	●	●	●	●	-	Z	W	6	3
						210	275	800	3	A	E	5	6	6	4	-	1	■	■	●	●	●	●	●	●	-	Z	W	6	3
						275	1250	3	A	E	5	6	6	4	-	2	■	■	●	●	●	●	●	●	●	-	Z	W	6	3
						210	275	1600	3	A	E	5	6	6	4	-	3	■	■	●	●	●	●	●	●	-	Z	W	6	3
			31.5	80/82	160	275	800	3	A	E	5	6	2	5	-	1	■	■	●	●	●	●	●	●	-	Z	W	6	3	
						275	1250	3	A	E	5	6	2	5	-	2	■	■	●	●	●	●	●	●	●	-	Z	W	6	3
						210	275	1250	3	A	E	5	6	6	5	-	2	■	■	●	●	●	●	●	●	-	Z	W	6	3
						275	1600	3	A	E	5	6	6	5	-	3	■	■	●	●	●	●	●	●	●	-	Z	W	6	3
						275	2500	3	A	E	5	6	6	5	-	6	■	■	●	●	●	●	●	●	●	-	Z	W	6	3

1) W63 is absolutely necessary as order code

*) Can also be ordered without withdrawable part, see page 37, 13th position

**) As a difference, other insulating shells are also possible, see page 37

Legend: ● With contact system
■ Without contact system

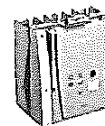

17.5 kV

Rated voltage for 50/60 Hz U_n kV	Rated lightning impulse voltage U_p kV	Rated short-duration power-frequency withstand voltage U_b kV	Rated short-circuit breaking current with 36% DC component I_{sc} kA	Rated short-circuit making current (at 50/60 Hz) I_{ma} kA	Pole-center distance mm	Width across flats mm	Rated normal current I_n A	Position: 1 2 3 4 5 6 7 - 8 9-12												13th position = Equipment package		14-16		Order codes				
								3	A	E	1	■	■	■	■	■	■	■	■	■	■	■	■	■	■	■	■	■
								Article No.:																				
								Orderable versions																				
								Circuit breaker for fixed mounting, without circuit breaker installation accessories																				
								On withdrawable part																				
								On withdrawable part with complete contact system *																				
								On withdrawable part with complete contact system and bushings *																				
								Withdrawable module without earthing switch																				
								Withdrawable module with earthing switch																				
								See pages 35 and 36																				
								See pages 38 to 40																				
								See page 41																				
17.5	95	38	40	100/104	275	310	1250	3	A	E	1	6	5	6	-	2	■	■	●	●	-	Z	D	9	0**			
						310	2000	3	A	E	1	6	5	6	-	4	■	■	●	●	-	Z	D	9	0**			
						310	2500	3	A	E	1	6	5	6	-	6	■	■	●	●	-	Z	D	9	0**			
						310	3150	3	A	E	1	6	5	6	-	7	■	■	●	●	-	Z	D	9	0**			
					210	310	1250	3	A	E	1	2	8	6	-	2	■	■	●	●	●	●	-	Z	D	9	0**	
						310	2000	3	A	E	1	2	8	6	-	4	■	■	●	●	●	●	-	Z	D	9	0**	
						310	2500	3	A	E	1	2	8	6	-	6	■	■	●	●	●	●	-	Z	D	9	0**	
						310	3150	3	A	E	1	2	8	6	-	7	■	■	●	●	●	●	-	Z	D	9	0**	
Circuit breaker for installation in NXAIR World 1)																												
						40	100/104	210	275	1250	3	A	E	1	6	6	6	-	2	■	■	●	●	-	Z	W	6	3
									275	2500	3	A	E	1	6	6	6	-	6	■	■	●	●	-	Z	W	6	3
									275	3150	3	A	E	1	6	6	6	-	7	■	■	●	●	-	Z	W	6	3

Legend: ● With contact system ■ Without contact system

- 1) W63 is absolutely necessary as order code
- *) Can also be ordered without withdrawable part, see page 37, 13th position
- **) As a difference, other insulating shells are also possible, see page 37

2

[Handwritten signature]

[Handwritten signature]



[Handwritten signature]

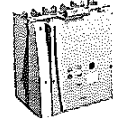

24 kV

Position: 1 2 3 4 5 6 7 - 8 9-12

13th position = Equipment package 14-16

Order codes

Article No.: 3 A E 1

Orderable versions

Rated voltage for 50/60 Hz U_r kV	Rated lightning impulse voltage U_p kV	Rated short-duration power-frequency withstand voltage U_d kV	Rated short-circuit breaking current with 36% DC component I_{br} kA	Rated short-circuit making current (at 50/60 Hz) I_m kA	Pole-center distance mm	Width across flats mm	Rated normal current I_r A	1	2	3	4	5	6	7	-	8	9-12	13th position = Equipment package	14-16	Order codes																
24	125	50	16	40/42	210	310	800	3	A	E	1	3	2	2	-	1																				
							1250	3	A	E	1	3	2	2	-	2																				
							2000	3	A	E	1	3	2	2	-	4																				
							275	800	3	A	E	1	3	5	2	-	1																			
								1250	3	A	E	1	3	5	2	-	2																			
								2000	3	A	E	1	3	5	2	-	4																			
	125	50	20	50/52	210	310	800	3	A	E	1	3	2	3	-	1																				
							1250	3	A	E	1	3	2	3	-	2																				
							2000	3	A	E	1	3	2	3	-	4																				
							275	2500	3	A	E	1	3	2	3	-	6																			
								800	3	A	E	1	3	5	3	-	1																			
								1250	3	A	E	1	3	5	3	-	2																			
125	50	25	63/65	210	310	800	3	A	E	1	3	2	4	-	1																					
						1250	3	A	E	1	3	2	4	-	2																					
						2000	3	A	E	1	3	2	4	-	4																					
						275	2500	3	A	E	1	3	2	4	-	6																				
							800	3	A	E	1	3	5	4	-	1																				
							1250	3	A	E	1	3	5	4	-	2																				
24	125	50	25	63/65	210	310	2000	3	A	E	1	3	5	4	-	4																				
							2500	3	A	E	1	3	5	4	-	6																				
							275	800	3	A	E	1	3	5	4	-	1																			
								1250	3	A	E	1	3	5	4	-	2																			
								2000	3	A	E	1	3	5	4	-	4																			
							2500	3	A	E	1	3	5	4	-	6																				
Special version $U_d = 55$ kV																			-	Z	E	5	5 ¹⁾													
Special version $U_d = 65$ kV																			-	Z	E	6	5 ²⁾													
Circuit breaker for installation in NXAIR World ³⁾																																				
24	125	50	25	63/65	210	310	1250	3	A	E	1	7	1	4	-	2					-	Z	W	6	3											
							275	310	2000	3	A	E	1	7	4	4	-	4																		
							310	2500	3	A	E	1	7	4	4	-	6																			
Special version $U_d = 55$ kV																																				

See pages 35 and 36

See pages 38 to 40

See page 41

2

- 1) With special version E55 (selection is possible if 13th position is 0, 1, 2, 3 and 5)
 - 2) With special version E65 (selection is possible if 13th position is 0 and 1)
 - 3) W63 is absolutely necessary as order code
- Legend: ● With contact system
■ Without contact system

*) Can also be ordered without withdrawable part, see page 37, 13th position

Handwritten signature

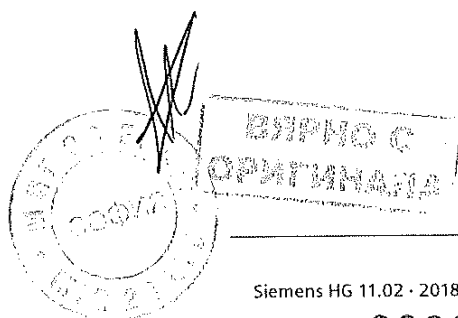

Device selection
Secondary equipment

SION Vacuum Circuit Breakers 3AE5 and 3AE1

9th position

Position: 1 2 3 4 5 6 7 8 9 10 11 12 13 14 15 16 Order codes

Release combination 1)

Article No.:



2

1st shunt release	2nd shunt release	3rd shunt release	Undervoltage release	Current-transformer-operated release 0.5 A 2)	Current-transformer-operated release 1.0 A	Current-transformer-operated release with tripping pulse 0.1 Ws (20 C)
-------------------	-------------------	-------------------	----------------------	---	--	--

I	II	III				
I	II			II		II
I	III		II		II	
I	II		II	III		
I	II				III	
I	II			II + III		III
I			II	III		
I	II		II		III	III
I			I	II		II
I					II	I

See page 36
See page 36
See page 38
See page 39
See page 40
See page 41

A				
B				
B	Not for 3AE1	- Z	F 1 5	
C				
G				
H				
F				
S	Not for 3AE1			
T	Not for 3AE1			
T	Not for 3AE1	- Z	A 4 6	
T	Not for 3AE1	- Z	A 4 5	
U	Not for 3AE1			
V	Not for 3AE1			
V	Not for 3AE1	- Z	A 4 6	
V	Not for 3AE1	- Z	A 4 5	
E	Not for 3AE5			
N	Not for 3AE5			
P	Not for 3AE5			
Q	Not for 3AE5			
J	Not for 3AE5			
L	Not for 3AE5			
M	Not for 3AE5			

I = position of first release II = position of second release III = position of third release

- 1) Operating voltage is selected at positions 11 + 12 + order code for 3rd release
- 2) Special version with 5 A c.t.-operated release:
for all circuit breakers (except for retrofit) with 0.5 A c.t.-operated release can be ordered with order code A49

- Z A 4 9

Operating voltage of the 3rd release

Standard voltages	Special voltages
-------------------	------------------

24 V DC	B/S	- Z J 8 0
48 V DC	B/S	- Z J 8 3
60 V DC	B/S	- Z J 8 4
110 V DC	B/S	- Z J 8 5
220 V DC	B/S	- Z J 8 9
100 V AC 50/60 Hz 3)	B/S	- Z J 9 2
110 V AC 50/60 Hz 3)	B/S	- Z J 9 3
230 V AC 50/60 Hz 3)	B/S	- Z J 9 7
30 V DC	B/S	- Z J 8 1
32 V DC	B/S	- Z J 8 2
120 V DC	B/S	- Z J 8 6
125 V DC	B/S	- Z J 8 7
127 V DC	B/S	- Z J 8 8
240 V DC	B/S	- Z J 9 0
120 V AC 50/60 Hz 3)	B/S	- Z J 9 5
125 V AC 50/60 Hz 3)	B/S	- Z J 9 6
240 V AC 50/60 Hz 3)	B/S	- Z J 9 8

3) The AC frequency 50 or 60 Hz is selected at the 16th position of the article number together with the language (see page 40)

12th position Operating voltage of the 2nd release		Position:	1	2	3	4	5	6	7	-	8	9	10	11	12	-	13	14	15	16	Order codes	
		Article No.:	3	A	E															*		
Standard voltages	Special voltages																					
None or c.t.-operated release																						
24 V DC																						
48 V DC																						
60 V DC																						
110 V DC																						
220 V DC																						
100 V AC	50/60 Hz ¹⁾																					
110 V AC	50/60 Hz ¹⁾																					
230 V AC	50/60 Hz ¹⁾																					
		30 V DC																				
		32 V DC																				
		120 V DC																				
		125 V DC																				
		127 V DC																				
		240 V DC																				
		120 V AC	50/60 Hz ¹⁾																			
		125 V AC	50/60 Hz ¹⁾																			
		240 V AC	50/60 Hz ¹⁾																			

See page 38
See page 39
See page 40
See page 41



1) The AC frequency 50 or 60 Hz is selected at the 16th position of the article number together with the language (see page 40)

13th position	Position:	1	2	3	4	5	6	7	-	8	9	10	11	12	-	13	14	15	16	Order codes	
Circuit breaker installation accessories	Article No.:	3	A	E															*		
Options																					
Circuit breaker for fixed mounting																					
Without circuit breaker installation accessories, circuit breaker for fixed mounting																				0	
Circuit breaker prepared for separate mounting of withdrawable part																					
Without withdrawable part, with contact arms, contacts ¹⁾ , wiring of withdrawable part (loose delivery)																				2 - Z M 2 2	
Without withdrawable part, with contact arms, contacts ¹⁾ , fixed contacts, bushings, wiring of withdrawable part (supplied loose)																				3 - Z M 2 3	
Circuit breaker on withdrawable part																					
On withdrawable part																					1
On withdrawable part, with contact arms, contacts ¹⁾																					2
On withdrawable part, with contact arms, contacts ¹⁾ , fixed contacts, bushings																					3
Withdrawable module																					
Circuit breaker on withdrawable part, with cartridge, contact arms, contacts ¹⁾ , fixed contacts, bushings, shutters																					5
Circuit breaker on withdrawable part, with cartridge, contact arms, contacts ¹⁾ , fixed contacts, bushings, shutters, earthing switch with short-circuit making capacity																					6

See page 38
See page 39
See page 40
See page 41

2

1) Special version: Contact with 13 contact fingers (only up to 1250 A and 31.5 kA) can be ordered with order code Z-M13

Not for 3AE5

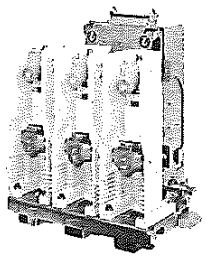

Example: Circuit breaker for fixed mounting

RHGT1-375 UF

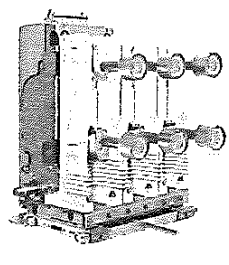

Example: Circuit breaker on withdrawable part with contact arms and contacts

RHGT1-375 UF

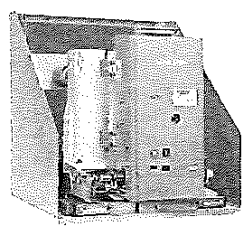

Example: Circuit breaker with withdrawable module

RHGT1-376 UF

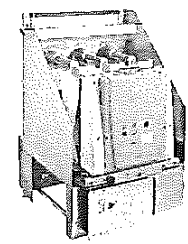

Example: Circuit breaker with withdrawable module and earthing switch

RHGT1-352 APS

[Handwritten signatures]

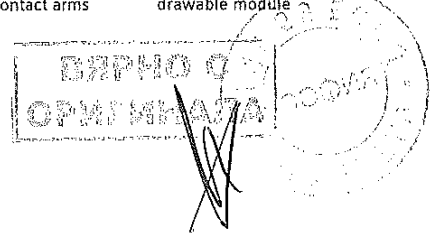

Device selection Secondary equipment

14th position

Position: 1 2 3 4 5 6 7 - 8 9 10 11 12 - 13 14 15 16 Order codes

Operating voltage of the drive motor

Article No.: 3 A E - -

Standard voltages	Special voltages
24 V DC 1)	
48 V DC	
60 V DC	
110 V DC	
220 V DC	
100 V AC 50/60 Hz 1) 2)	
110 V AC 50/60 Hz 1) 2)	
230 V AC 50/60 Hz 2)	
	30 V DC 1)
	32 V DC 1)
	120 V DC
	125 V DC
	127 V DC
	240 V DC
	120 V AC 50/60 Hz 2)
	125 V AC 50/60 Hz 2)
	240 V AC 50/60 Hz 2)

B
 C
 D
 E
 F
 H
 J
 K
 M
 N
 P
 Q
 R
 S
 U
 V
 W

S: page 39
S: page 40
S: page 41

2

1) Does not apply to a rated short-circuit breaking current of 40 kA
2) The AC frequency 50 or 60 Hz is selected at the 16th position of the article number together with the language (see page 40)

16th position

Position: 1 2 3 4 5 6 7 - 8 9 10 11 12 - 13 14 15 16

Article No.: 3 AE - - - - - - - - - - - - - - - *

Order codes

Languages of operating instructions and rating plate; AC frequency of operating voltages 1)

Language selection				Frequency selection				
German	English	French	Spanish	50 Hz DC or AC	60 Hz			
<input checked="" type="checkbox"/>	<input type="checkbox"/>	<input type="checkbox"/>	<input type="checkbox"/>	<input checked="" type="checkbox"/>	<input type="checkbox"/>		0	
<input checked="" type="checkbox"/>	<input type="checkbox"/>	<input type="checkbox"/>	<input type="checkbox"/>	<input type="checkbox"/>	<input checked="" type="checkbox"/>		1	
<input type="checkbox"/>	<input checked="" type="checkbox"/>	<input type="checkbox"/>	<input type="checkbox"/>	<input type="checkbox"/>	<input type="checkbox"/>		2	
<input type="checkbox"/>	<input type="checkbox"/>	<input checked="" type="checkbox"/>	<input type="checkbox"/>	<input type="checkbox"/>	<input checked="" type="checkbox"/>		3	
<input type="checkbox"/>	<input type="checkbox"/>	<input type="checkbox"/>	<input checked="" type="checkbox"/>	<input type="checkbox"/>	<input checked="" type="checkbox"/>		4	
<input type="checkbox"/>	<input type="checkbox"/>	<input type="checkbox"/>	<input type="checkbox"/>	<input checked="" type="checkbox"/>	<input type="checkbox"/>		5	
<input type="checkbox"/>	<input type="checkbox"/>	<input type="checkbox"/>	<input checked="" type="checkbox"/>	<input type="checkbox"/>	<input checked="" type="checkbox"/>		6	
<input type="checkbox"/>	<input type="checkbox"/>	<input type="checkbox"/>	<input type="checkbox"/>	<input type="checkbox"/>	<input type="checkbox"/>		7	
Special versions								
Portuguese, 50 Hz or DC							9	R 1 C
Portuguese, 60 Hz							9	R 1 D
Italian, DC or AC 50 Hz							9	R 1 F
Russian, DC or AC 50 Hz							9	R 1 G
Russian, 60 Hz							9	R 1 H
Polish, DC or AC 50 Hz							9	R 1 K
Other languages on request								

See page 41

2

1) AC voltage refers to the low-voltage equipment

Additional equipment

Options	Position:		Article No.:																Order codes			
	Circuit breaker 13th position = 0, 1, 2, 3	Withdrawable mod- ule, 13th position = 5, 6	3AE1	3AE5	1	2	3	4	5	6	7	8	9	10	11	12	13	14	15	16		
Wire ends with marking at the plug connector	<input checked="" type="checkbox"/>	<input checked="" type="checkbox"/>	<input checked="" type="checkbox"/>	<input checked="" type="checkbox"/>																		- Z A 0 5
Wiring cables halogen-free and flame-retardant	<input checked="" type="checkbox"/>	<input checked="" type="checkbox"/>	<input checked="" type="checkbox"/>	<input checked="" type="checkbox"/>																		- Z A 1 0
"Destination end marking at wire ends + wire end ferrules pulled out without plug (must be ordered with B01 to B08)"	<input checked="" type="checkbox"/>	<input checked="" type="checkbox"/>	<input checked="" type="checkbox"/>	<input checked="" type="checkbox"/>																		- Z A 1 1
Wiring cables tinned	<input checked="" type="checkbox"/>	<input checked="" type="checkbox"/>	<input checked="" type="checkbox"/>	<input checked="" type="checkbox"/>																		- Z A 1 2
Flat connector with insulating sleeve	<input checked="" type="checkbox"/>	<input checked="" type="checkbox"/>	<input checked="" type="checkbox"/>	<input checked="" type="checkbox"/>																		- Z A 1 3
gold-plated auxiliary switch 12 NO + 12 NC and 64-pole plug	<input checked="" type="checkbox"/>	<input checked="" type="checkbox"/>	<input checked="" type="checkbox"/>	<input checked="" type="checkbox"/>																		- Z A 2 1
Anti-condensation heating for 110 V AC, 50 W	<input checked="" type="checkbox"/>	<input checked="" type="checkbox"/>	<input checked="" type="checkbox"/>	<input checked="" type="checkbox"/>																		- Z A 2 9
Anti-condensation heating for 230 V AC, 50 W	<input checked="" type="checkbox"/>	<input checked="" type="checkbox"/>	<input checked="" type="checkbox"/>	<input checked="" type="checkbox"/>																		- Z A 3 0
Version free of silicone emissions	<input checked="" type="checkbox"/>	<input checked="" type="checkbox"/>	<input checked="" type="checkbox"/>	<input checked="" type="checkbox"/>																		- Z A 3 1
Circuit breaker for operation at ambient air temperatures down to -25 °C	<input checked="" type="checkbox"/>	<input checked="" type="checkbox"/>	<input checked="" type="checkbox"/>	<input checked="" type="checkbox"/>																		- Z A 4 0
Electrical closing lockout not together with key-operated interlock	<input checked="" type="checkbox"/>	<input checked="" type="checkbox"/>	<input checked="" type="checkbox"/>	<input checked="" type="checkbox"/>																		- Z A 4 7
C.t.-operated release 5 A	<input checked="" type="checkbox"/>	<input checked="" type="checkbox"/>	<input checked="" type="checkbox"/>	<input checked="" type="checkbox"/>																		- Z A 4 9
Additional rating plate, supplied loose	<input checked="" type="checkbox"/>	<input checked="" type="checkbox"/>	<input checked="" type="checkbox"/>	<input checked="" type="checkbox"/>																		- Z B 0 0
Cable harness 800 mm, pulled out	<input checked="" type="checkbox"/>	<input checked="" type="checkbox"/>	<input checked="" type="checkbox"/>	<input checked="" type="checkbox"/>																		- Z B 0 1
Cable harness 500 mm, pulled out	<input checked="" type="checkbox"/>	<input checked="" type="checkbox"/>	<input checked="" type="checkbox"/>	<input checked="" type="checkbox"/>																		- Z B 0 2
Cable harness 2000 mm, pulled out	<input checked="" type="checkbox"/>	<input checked="" type="checkbox"/>	<input checked="" type="checkbox"/>	<input checked="" type="checkbox"/>																		- Z B 0 3
Cable harness 1200 mm, pulled out	<input checked="" type="checkbox"/>	<input checked="" type="checkbox"/>	<input checked="" type="checkbox"/>	<input checked="" type="checkbox"/>																		- Z B 0 4
Cable harness 1500 mm, pulled out	<input checked="" type="checkbox"/>	<input checked="" type="checkbox"/>	<input checked="" type="checkbox"/>	<input checked="" type="checkbox"/>																		- Z B 0 5
Cable harness 2500 mm, pulled out (not with 24 V DC control voltage)	<input checked="" type="checkbox"/>	<input checked="" type="checkbox"/>	<input checked="" type="checkbox"/>	<input checked="" type="checkbox"/>																		- Z B 0 6
Cable harness 3000 mm, pulled out (not with 24 V DC control voltage)	<input checked="" type="checkbox"/>	<input checked="" type="checkbox"/>	<input checked="" type="checkbox"/>	<input checked="" type="checkbox"/>																		- Z B 0 7
Cable harness 3500 mm, pulled out (not with 24 V DC control voltage)	<input checked="" type="checkbox"/>	<input checked="" type="checkbox"/>	<input checked="" type="checkbox"/>	<input checked="" type="checkbox"/>																		- Z B 0 8
Cable harness of withdrawable part	<input checked="" type="checkbox"/>	<input checked="" type="checkbox"/>	<input checked="" type="checkbox"/>	<input checked="" type="checkbox"/>																		- Z B 1 3
Sleeve housing PG21/PG29 at pulled out cable harness (B01-B08) for all versions except 13th position = 7	<input checked="" type="checkbox"/>	<input checked="" type="checkbox"/>	<input checked="" type="checkbox"/>	<input checked="" type="checkbox"/>																		- Z B 1 6
Without upper part of plug	<input checked="" type="checkbox"/>	<input checked="" type="checkbox"/>	<input checked="" type="checkbox"/>	<input checked="" type="checkbox"/>																		- Z B 2 3
Without supplementary equipment	<input checked="" type="checkbox"/>	<input checked="" type="checkbox"/>	<input checked="" type="checkbox"/>	<input checked="" type="checkbox"/>																		- Z B 2 4
Close-open solenoids with thermo switch (only valid for 60 V/110 V/220 V DC)	<input checked="" type="checkbox"/>	<input checked="" type="checkbox"/>	<input checked="" type="checkbox"/>	<input checked="" type="checkbox"/>																		- Z B 4 7
Cable harness with double insulation for ship-building industry	<input checked="" type="checkbox"/>	<input checked="" type="checkbox"/>	<input checked="" type="checkbox"/>	<input checked="" type="checkbox"/>																		- Z B 5 8
Special circuit diagram	<input checked="" type="checkbox"/>	<input checked="" type="checkbox"/>	<input checked="" type="checkbox"/>	<input checked="" type="checkbox"/>																		- Z B 9 9
For aggressive ambient conditions:	<input checked="" type="checkbox"/>	<input checked="" type="checkbox"/>	<input checked="" type="checkbox"/>	<input checked="" type="checkbox"/>																		- Z D 2 0
Gold-plated contacts, tinned pole side, ...	<input checked="" type="checkbox"/>	<input checked="" type="checkbox"/>	<input checked="" type="checkbox"/>	<input checked="" type="checkbox"/>																		- Z D 2 2
Withdrawable part with 220 mm racking path	<input checked="" type="checkbox"/>	<input checked="" type="checkbox"/>	<input checked="" type="checkbox"/>	<input checked="" type="checkbox"/>																		- Z D 2 3
Withdrawable part with 200 mm racking path	<input checked="" type="checkbox"/>	<input checked="" type="checkbox"/>	<input checked="" type="checkbox"/>	<input checked="" type="checkbox"/>																		- Z D 2 4
Withdrawable part with 180 mm racking path	<input checked="" type="checkbox"/>	<input checked="" type="checkbox"/>	<input checked="" type="checkbox"/>	<input checked="" type="checkbox"/>																		- Z D 5 5
IP plate	<input checked="" type="checkbox"/>	<input checked="" type="checkbox"/>	<input checked="" type="checkbox"/>	<input checked="" type="checkbox"/>																		- Z D 5 6
Shaft cover	<input checked="" type="checkbox"/>	<input checked="" type="checkbox"/>	<input checked="" type="checkbox"/>	<input checked="" type="checkbox"/>																		- Z D 5 9
Wide operating mechanism box ¹⁾	<input checked="" type="checkbox"/>	<input checked="" type="checkbox"/>	<input checked="" type="checkbox"/>	<input checked="" type="checkbox"/>																		- Z D 9 0
Long insulating shell (standard)	<input checked="" type="checkbox"/>	<input checked="" type="checkbox"/>	<input checked="" type="checkbox"/>	<input checked="" type="checkbox"/>																		- Z D 9 1
Insulating shell (shortened version, for 24 kV)	<input checked="" type="checkbox"/>	<input checked="" type="checkbox"/>	<input checked="" type="checkbox"/>	<input checked="" type="checkbox"/>																		- Z D 9 2
Insulating shell, width across flats 275 mm for GT system	<input checked="" type="checkbox"/>	<input checked="" type="checkbox"/>	<input checked="" type="checkbox"/>	<input checked="" type="checkbox"/>																		- Z D 9 3
Insulating shell for Minis system	<input checked="" type="checkbox"/>	<input checked="" type="checkbox"/>	<input checked="" type="checkbox"/>	<input checked="" type="checkbox"/>																		- Z D 9 4
Insulating shell to contact arm side (completely shortened)	<input checked="" type="checkbox"/>	<input checked="" type="checkbox"/>	<input checked="" type="checkbox"/>	<input checked="" type="checkbox"/>																		- Z D 9 5
Insulating shell to contact arm side (special version for NXAIR World and 3AE5)	<input checked="" type="checkbox"/>	<input checked="" type="checkbox"/>	<input checked="" type="checkbox"/>	<input checked="" type="checkbox"/>																		- Z E 1 3
Rated short-duration power-frequency withstand voltage 42 kV (at 12 kV)	<input checked="" type="checkbox"/>	<input checked="" type="checkbox"/>	<input checked="" type="checkbox"/>	<input checked="" type="checkbox"/>																		- Z E 1 3

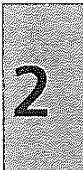

On request

¹⁾ For further options, see page 17

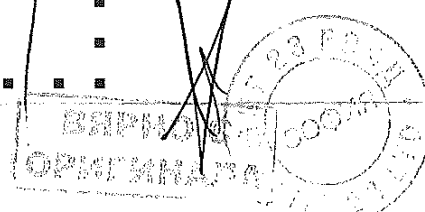

Ordering information for accessories and spare parts

The article numbers in the spare part overviews are valid for currently manufactured vacuum circuit breakers. When mounting parts or spare parts are being ordered for an existing vacuum circuit breaker, always quote the type designation, serial number and the year of manufacture of the circuit breaker to be sure to get the correct parts.

Retrofitting

When releases / solenoids are retrofitted, the article numbers of the mounting parts must also be specified. For other additional equipment, the required mounting parts are included in the scope of supply.

Spare parts may only be replaced by qualified personnel.

Accessories for the plug connector

Included in the scope of supply of the basic equipment for 3AE vacuum circuit breakers:

For 24-pole plug connector

- Lower part of plug
- Crimp sockets according to number of contacts
- Upper part of plug with screwed contacts (no crimp sockets required)

For 64-pole plug connector

- Lower part of plug
- Upper part of plug
- Crimp sockets according to number of contacts

Rating plate

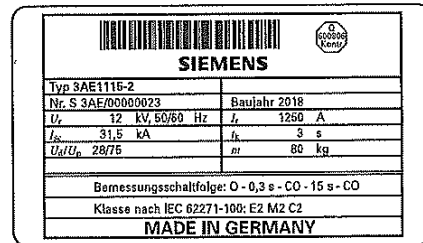

HG11-2518r_06 eps

2

Note:

The following 3 details are necessary for any query regarding spare parts, subsequent deliveries, etc.:

- Type designation
- Serial No.
- Year of manufacture

Designation	Description	Feature	Article No.
Handles	Hand crank for circuit breaker		3AX15 30-4B
	Long hand crank for circuit breaker		3AX14 30-2B
	Handle for withdrawable part		3AX14 30-2C
	Handle for earthing switch (for modules up to 31.5 kA)		3AX14 30-2D
	Handle for earthing switch (for 40 kA modules)		3AX14 30-3D
Lubricants	180 g of Klüber-Isoflex Topas L32N		3AX11 33-3H
	1 kg of Klüber-Isoflex Topas L32N		3AX11 33-3E
	1 kg Molykote grease		3AX11 33-2L
Closing solenoid	1 kg Vaseline, Atlantic		3AX11 33-4A
	Used as closing solenoid or 1st shunt release		
	For 3AE1	24 V DC	3AY15 10-5K
	For 3AE1	30/32 V DC	3AY15 10-5M
	For 3AE1	48 V DC	3AY15 10-5C
	For 3AE1	60 V DC	3AY15 10-5D
	For 3AE1	100/124 V DC	3AY15 10-5E
	For 3AE1	125/144 V DC	3AY15 10-5L
	For 3AE1	220/250 V DC	3AY15 10-5F
	For 3AE1	100/125 V AC, 50/60 Hz	3AY15 10-5E
For 3AE1	230/240 V AC, 50/60 Hz	3AY15 10-5F	

Position: 1 - 9

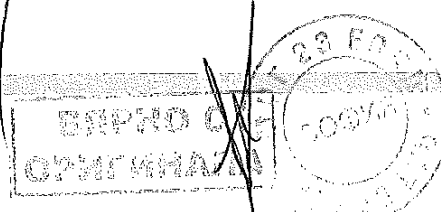

Device selection

Accessories and spare parts

SION Vacuum Circuit Breakers 3AE5 and 3AE1

			Position:	1 – 9
Designation	Description	Feature	Article No.	
Closing solenoid (continued)	For 3AE5	24 – 32 V DC	3AY14 10-0B	
	For 3AE5	48 V DC	3AY14 10-0C	
	For 3AE5	60 V DC	3AY14 10-0D	
	For 3AE5	110 – 127 V DC	3AY14 10-0E	
	For 3AE5	220 – 240 V DC	3AY14 10-0F	
	For 3AE5	100/125 V AC, 50/60 Hz	3AY14 10-0J	
2nd and 3rd Shunt release	For 3AE1 and 3AE5	24 – 32 V DC	3AX11 01-2B	
	For 3AE1 and 3AE5	48 – 60 V DC	3AX11 01-2C	
	For 3AE1 and 3AE5	110 – 127 V DC	3AX11 01-2E	
	For 3AE1 and 3AE5	220 – 240 V DC	3AX11 01-2F	
	For 3AE1 and 3AE5	100 – 125 V AC, 50 Hz	3AX11 01-2G	
	For 3AE1 and 3AE5	230 – 240 V AC, 50 Hz	3AX11 01-2J	
	For 3AE1 and 3AE5	100 – 125 V AC, 60 Hz	3AX11 01-3G	
	For 3AE1 and 3AE5	230 – 240 V AC, 60 Hz	3AX11 01-3J	
Current-transformer- operated release	For rated normal current 0.5 A	For 3AE1 and 3AE5	3AX11 02-2A	
	For rated normal current 1 A	For 3AE1 and 3AE5	3AX11 02-2B	
	For tripping impulse ≥ 0.1 Ws, 20 Ω for 7SJ45 protection relay	For 3AE1 and 3AE5	3AX11 04-2B	
	For rated normal current 5 A incl. rectifier	For 3AE1	3AX14 02-2D	
Mounting parts	For rated normal current 5 A incl. rectifier	For 3AE5	3AX14 02-2E	
	For 2nd shunt release / c.t.-operated release	for 3AE1	3AX14 11-2A	
		For 3AE5	3AX14 11-5A	
	For 2nd and 3rd release	for 3AE5	3AX14 11-5B	
Undervoltage release	For 3AE1 and 3AE5	24 V DC	3AX11 03-2B	
	For 3AE1 and 3AE5	30/32 V DC	3AX11 03-2L	
	For 3AE1 and 3AE5	48 V DC	3AX11 03-2C	
	For 3AE1 and 3AE5	60 V DC	3AX11 03-2D	
	For 3AE1 and 3AE5	110 V DC	3AX11 03-2E	
	For 3AE1 and 3AE5	120/127 V DC	3AX11 03-2N	
	For 3AE1 and 3AE5	220 V DC	3AX11 03-2F	
	For 3AE1 and 3AE5	240 V DC	3AX11 03-2P	
	For 3AE1 and 3AE5	100 V AC, 50 Hz	3AX11 03-2G	
	For 3AE1 and 3AE5	110/125 V AC, 50 Hz	3AX11 03-2H	
	For 3AE1 and 3AE5	230 V AC, 50 Hz	3AX11 03-2J	
	For 3AE1 and 3AE5	240 V AC, 50 Hz	3AX11 03-2M	
	For 3AE1 and 3AE5	100 V AC, 60 Hz	3AX11 03-3G	
	For 3AE1 and 3AE5	110/125 V AC, 60 Hz	3AX11 03-3H	
	For 3AE1 and 3AE5	230 V AC, 60 Hz	3AX11 03-3J	
For 3AE1 and 3AE5	240 V AC, 60 Hz	3AX11 03-3M		
Mounting parts	For undervoltage releases	For 3AE1	3AX14 13-2A	
		For 3AE5	3AX14 13-5A	
Drive motor	For 3AE1	24/30/32 V DC	3AY17 11-2B	
	For 3AE1	48 V DC	3AY17 11-2C	
	For 3AE1	60 V DC	3AY17 11-2D	
	For 3AE1	100/110/125 V DC/AC	3AY17 11-2E	
	For 3AE1	220 - 240 V DC	3AY17 11-2F	
	For 3AE5	24/30/32 V DC	3AY14 11-1B	
	For 3AE5	48/60 V DC	3AY14 11-1C	
	For 3AE5	110 – 127 V DC	3AY14 11-1E	
		100 – 125 V AC		
	For 3AE5	220 – 240 V DC	3AY14 11-1F	
	220 – 240 V AC			

				Position:	1 - 9
Designation	Description	Feature		Article No.	
Auxiliary contactor	Type 3RH11 22 For anti-pumping	For 3AE1	24 V DC	SWB: 55656	
		For 3AE1	30/32 V DC	SWB: 55658	
		For 3AE1	48 V DC	SWB: 55659	
		For 3AE1	60 V DC	SWB: 55660	
		For 3AE1	110 V DC	SWB: 55661	
		For 3AE1	120/127 V DC	SWB: 55662	
		For 3AE1	220 V DC	SWB: 55663	
		For 3AE1	240/250 V DC	SWB: 55665	
		For 3AE1	110 V AC, 50/60 Hz	SWB: 55666	
		For 3AE1	120 V AC, 50/60 Hz	SWB: 55667	
		For 3AE1	125 V AC, 50/60 Hz	SWB: 55668	
		For 3AE1	230 V AC, 50/60 Hz	SWB: 55669	
		For 3AE1	240 V AC, 50/60 Hz	SWB: 55670	
		Electronic module	For 3AE5		24 - 60 V DC
	110 - 240 V DC			3AY14 20-1E	
	100 - 240 V AC			3AX42 06-0A	
Position switches	Type SE4 without mounting accessories Used for:		Quantity		
		- Electrical anti-pumping (-S3)	1		
		- Electrical interlocking (-S12)	1		
		- Motor control (-S21, -S22)	2		
		- Closing spring charged (-S4)	1		
		- Circuit breaker tripping signal (-S6)	1		
		- Electrical closing lock-out (-S5)	1		
		- Withdrawable part (-S1.0 to -S1.9)	10		
		- Key-operated interlock	1		
		Auxiliary switches (-S1)	6 NO + 6 NC 12 NO + 12 NC		
				3SV92 74-2AA0	
Mechanical interlocking		for 3AE1		3AX14 20-2A	
		For 3AE1	≤ 12 kV ≤ 25 kA ≤ 1250 A	3AX14 20-2B	
Key-operated interlocking		For 3AE1		3AX14 37-3A	
		For 3AE1	≤ 12 kV ≤ 25 kA ≤ 1250 A	3AX14 37-3B	
		for 3AE5		3AX14 37-4A	
Accessories for Plug connection	Mounting kit Crimp pins (for conductor cross-section 1.5 mm) Crimp pins (for lower part of plug) Crimp sockets (for upper part of plug) Crimping pliers Disassembly tool Plug connection, complete Plug connection (lower part) Plug connection (upper part) Plug connection (lower part) Plug connection (upper part)	For 3AE1 and 3AE5	24-pole	3AX11 34-3A	
		For 3AE1 and 3AE5	64-pole	3AX11 34-4B	
		For 3AE1 and 3AE5	64-pole	3AX11 34-4C	
		For 3AE1 and 3AE5		3AX11 34-4D	
		For 3AE1 and 3AE5		3AX11 34-4G	
		For 3AE1 and 3AE5	24-pole	3AX11 34-7A	
		For 3AE1 and 3AE5	64-pole	3AX11 34-6A	
		For 3AE1 and 3AE5	24-pole	3AX11 34-5D	
		For 3AE1 and 3AE5	24-pole	3AX11 34-5C	
		For 3AE1 and 3AE5	64-pole	3AX11 34-5B	
For 3AE1 and 3AE5	64-pole	3AX11 34-5A			
Electrical closing lock-out		For 3AE1 and 3AE5	24 V DC	3AX14 05-2B	
		For 3AE1 and 3AE5	30/32 V DC	3AX14 05-2K	
		For 3AE1 and 3AE5	48 V DC	3AX14 05-2C	
		For 3AE1 and 3AE5	60 V DC	3AX14 05-2D	
		For 3AE1 and 3AE5	100/127 V DC	3AX14 05-2E	
		For 3AE1 and 3AE5	220/240 V DC	3AX14 05-2F	
		For 3AE1 and 3AE5	100 V AC, 50/60 Hz	3AX14 05-2G	
		For 3AE1 and 3AE5	100/125 V AC, 50/60 Hz	3AX14 05-2H	
		For 3AE1 and 3AE5	220/240 V AC, 50/60 Hz	3AX14 05-2J	
		For 3AE1		3AX14 15-2A	
		For 3AE5	≤ 12 kV ≤ 25 kA ≤ 1250 A	3AX14 15-2L	
Mounting parts	For electrical closing lock-out Circuit breaker tripping signal	For 3AE1		3AX14 15-3A	
		For 3AE1		3AX14 16-2A	

2

ВРНО С
ОУАИ ИНАТА

СИМЕНС

Designation	Description	Feature	Position:	1 – 9
				Article No.
Bushing complete	Pole-center distance: 150/160 mm	for 7.2 to 17.5 kV, 800 to 1600 A, up to 31.5 kA		3AX14 52-2A
	Pole-center distance: 210 mm	for 7.2 to 17.5 kV, 800 to 1600 A, up to 31.5 kA		3AX14 52-2B
	Pole-center distance: 210 mm	for 7.2 to 17.5 kV, 2000 to 2500 A, up to 31.5 kA		3AX14 52-2C
	Pole-center distance: 210 mm	for 24 kV, 800 to 1250 A, up to 25 kA		3AX14 52-2D
	Pole-center distance: 210 mm	for 24 kV, 2000 to 2500 A, up to 25 kA		3AX14 52-2E
	Pole-center distance: 275 mm	for 24 kV, 800 to 1250 A, up to 25 kA		3AX14 52-2F
	Pole-center distance: 275 mm	for 24 kV, 2000 to 2500 A, up to 25 kA		3AX14 52-2G
	Pole-center distance: 210/275 mm	for 7.2 to 17.5 kV, 1250 to 3150 A, 40 kA		3AX14 52-2H
Top cover for SION 3AE1	Top cover 150/160 mm pole-center distance	13th position = 0		3AX14 70-1A
		13th position – 1 – 6		3AX14 70-1B
		13th position – 1 – 6 with preparation for key-operated interlock (J60)		3AX14 70-1C
		13th position = 0 (neutral)		3AX14 70-1E
		13th position – 1 – 6 (neutral)		3AX14 70-1F
		13th position = 0		3AX14 70-2A
	Top cover 210 mm pole-center distance	13th position – 1 – 6		3AX14 70-2B
		13th position – 1 – 6 with preparation for key-operated interlock (J60)		3AX14 70-2C
		13th position = 0 (neutral)		3AX14 70-2E
		13th position – 1 – 6 (neutral)		3AX14 70-2F
		13th position = 0		3AX14 70-3A
		13th position – 1 – 6		3AX14 70-3B
	Top cover 275 mm pole-center distance	13th position – 1 – 6 with preparation for key-operated interlock (J60)		3AX14 70-3C
		13th position = 0 (neutral)		3AX14 70-3E
		13th position – 1 – 6 (neutral)		3AX14 70-3F
		Side cover 210 mm pole-center distance		3AX14 70-2S
		Side cover 275 mm pole-center distance		3AX14 70-3S
		Cover of low-voltage interface		3AX14 70-0H
Top cover for SION 3AE5	Plastic cover, standard		3AX14 70-5A	
	Plastic cover, neutral		3AX14 70-5B	
	Metal cover, PCD 150 mm	For 3AE5	3AX14 70-5C	
	Metal cover, PCD 160 mm	For 3AE5	3AX14 70-5D	
	Metal cover, PCD 210 mm	For 3AE5	3AX14 70-5E	
	Metal cover, PCD 275 mm	For 3AE5	3AX14 70-5F	
	Insulating shell towards contact arm side, for standard circuit breakers only for additional screening in case of narrow installation	Standard version, width across flats 310 mm	For 3AE1	7.2 to 17.5 kV (≤ 31.5 kA)
Standard version, width across flats 310 mm (Minis)		For 3AE1	7.2 to 17.5 kV (≤ 31.5 kA)	3AX14 38-4H
Standard version, width across flats 310 mm		For 3AE1	7.2 to 17.5 kV (40 kA)	3AX14 38-2E
Standard version, width across flats 275 mm		For 3AE1	7.2 to 17.5 kV	3AX14 38-2C
Standard version, width across flats 205 mm		For 3AE1	7.2 to 17.5 kV	3AX14 38-2D
Standard version, width across flats 205 mm (Minis)		For 3AE1	7.2 up to 17.5 kV (≤ 31.5 kA)	3AX14 38-4K
Standard version, width across flats 310 mm		For 3AE1	24 kV	3AX14 38-2B
Standard version, width across flats 310 mm		For 3AE1	24 kV	3AX14 38-3B
Standard version, width across flats 310 mm		For 3AE5	7.2 to 12 kV (≤ 25 kA ≤ 1250 A)	3AX14 38-5A
Shortened version, width across flats 310 mm		For 3AE5	7.2 to 12 kV (≤ 25 kA ≤ 1250 A)	3AX14 38-6A
Shortened version, width across flats 310 mm (Minis)		For 3AE5	7.2 to 12 kV (≤ 25 kA ≤ 1250 A)	3AX14 38-7A
Standard version, width across flats 275 mm		For 3AE5	7.2 to 12 kV (≤ 25 kA ≤ 1250 A)	3AX14 38-5C
Shortened version, width across flats 275 mm		For 3AE5	7.2 to 12 kV (≤ 25 kA ≤ 1250 A)	3AX14 38-6C
Standard version, width across flats 205 mm		For 3AE5	7.2 to 12 kV (≤ 25 kA ≤ 1250 A)	3AX14 38-5D
Shortened version, width across flats 205 mm		For 3AE5	7.2 to 12 kV (≤ 25 kA ≤ 1250 A)	3AX14 38-6D
Shortened version, width across flats 205 mm (Minis)		For 3AE5	7.2 to 12 kV (≤ 25 kA ≤ 1250 A)	3AX14 38-7D
Standard version, width across flats 310 mm		For 3AE5	7.2 to 12 kV (31.5 kA ≤ 1600 A)/17.5 kV (25 kA)	3AX14 38-5K
Shortened version, width across flats 310 mm (Minis)		For 3AE5	7.2 to 12 kV (31.5 kA ≤ 1600 A)/17.5 kV (25 kA)	3AX14 38-7K
Shortened version, width across flats 310 mm		For 3AE5	7.2 to 12 kV (31.5 kA ≤ 1600 A)/17.5 kV (25 kA)	3AX14 38-6K
Standard version, width across flats 275 mm		For 3AE5	7.2 to 12 kV (31.5 kA ≤ 1600 A)/17.5 kV (25 kA)	3AX14 38-5H
Shortened version, width across flats 275 mm		For 3AE5	7.2 to 12 kV (31.5 kA ≤ 1600 A)/17.5 kV (25 kA)	3AX14 38-6H
Standard version, width across flats 205 mm		For 3AE5	7.2 to 12 kV (31.5 kA ≤ 1600 A)/17.5 kV (25 kA)	3AX14 38-5J

				Position:	1 - 9
Designation	Description		Feature	Article No.	
Insulating shell towards contact arm side, for standard circuit breakers only for additional screening in case of narrow installation (continued)		Shortened version, width across flats 205 mm	For 3AE5	7.2 to 12 kV (31.5 kA ≤ 1600 A)/17.5 kV (25 kA)	3AX14 38-6J
		Shortened version, width across flats 205 mm (Minis)	For 3AE5	7.2 to 12 kV (31.5 kA ≤ 1600 A)/17.5 kV (25 kA)	3AX14 38-7H
		Shortened version, width across flats 205 mm (Ritter)	For 3AE5	7.2 to 12 kV (≤ 31.5 kA ≤ 1600 A)/17.5 kV (25 kA)	3AX14 38-5N
		Standard version (top)	For 3AE5	24 kV	3AX14 38-4B
		Standard version (bottom)	For 3AE5	24 kV	3AX14 38-5B
		Standard version for NXAIR	For 3AE5	7.2 to 12 kV (≤ 25 kA ≤ 1250A)	3AX14 38-5F
		Shortened version for NXAIR	For 3AE5	7.2 to 12 kV (≤ 25 kA ≤ 1250A)	3AX14 38-6F
		Special version for NXAIR (for D95)	For 3AE5	7.2 to 12 kV (≤ 25 kA ≤ 1250A)	3AX14 38-5Q
		Standard version for NXAIR	For 3AE5	7.2 to 12 kV (31.5 kA ≤ 1600 A)/17.5 kV (25 kA)	3AX14 38-6M
		Shortened version for NXAIR	For 3AE5	7.2 to 12 kV (31.5 kA ≤ 1600 A)/17.5 kV (25 kA)	3AX14 38-5M
		Special version for NXAIR (for D95)	For 3AE5	7.2 to 12 kV (31.5 kA ≤ 1600 A)/17.5 kV (25 kA)	3AX14 38-5P
		Shortened version for NXAIR (top)	For 3AE5	24 kV	3AX14 38-6B
	Shortened version for NXAIR (bottom)	For 3AE5	24 kV	3AX14 38-8B	
Gate for cartridge	Shortened version				3AX14 52-2B
Contact system	26 contact fingers		For 3AE1 and 3AE5	7.2/12/24 kV, 800 to 1250 A	3AX14 42-2A
	26 contact fingers		For 3AE1 and 3AE5	17.5 kV, 800 to 1250 A	3AX14 42-2B
	26 contact fingers		For 3AE1 and 3AE5	7.2/12/24 kV, up to 3150 A	3AX14 42-2C
	26 contact fingers		For 3AE1 and 3AE5	17.5 kV, up to 3150 A	3AX14 42-2D
	13 contact fingers		For 3AE1 and 3AE5	7.2/12/24 kV, 800 to 1250 A	3AX14 42-2E
	13 contact fingers		For 3AE1 and 3AE5	17.5 kV, 800 to 1250 A	3AX14 42-2F
Contact arm, complete with contact system	Width across flats: all	Contact fingers: 26	For 3AE1	7.2/12 kV, up to 31.5 kA, up to 1250 A	3AX14 43-2A
	Width across flats: all	Contact fingers: 26	For 3AE1	7.2/12 kV, up to 31.5 kA, up to 2500 A	3AX14 43-2B
	Width across flats: all	Contact fingers: 26	For 3AE1	17.5 kV, up to 31.5 kA, up to 1250 A	3AX14 43-2C
	Width across flats: all	Contact fingers: 26	For 3AE1	17.5 kV, up to 31.5 kA, up to 2500 A	3AX14 43-2D
	Width across flats: all	Contact fingers: 26	For 3AE1	24 kV, up to 25 kA, up to 1250 A	3AX14 43-2E
	Width across flats: all	Contact fingers: 26	For 3AE1	24 kV, up to 25 kA, up to 2500 A	3AX14 43-2F
	Width across flats: all	Contact fingers: 26	For 3AE1	7.2/12 kV, 40 kA, up to 1250 A	3AX14 43-2G
	Width across flats: all	Contact fingers: 26	For 3AE1	7.2/12 kV, 40 kA, up to 3150 A	3AX14 43-2H
	Width across flats: all	Contact fingers: 26	For 3AE1	17.5 kV, 40 kA, up to 1250 A	3AX14 43-2J
	Width across flats: all	Contact fingers: 26	For 3AE1	17.5 kV, 40 kA, up to 3150 A	3AX14 43-2K
	Width across flats: all	Contact fingers: 13	For 3AE1	7.2/12 kV, up to 31.5 kA, up to 1250 A	3AX14 43-2L
	Width across flats: all	Contact fingers: 13	For 3AE1	17.5 kV, up to 31.5 kA, up to 1250 A	3AX14 43-2M
	Width across flats: all	Contact fingers: 13	For 3AE1 and 3AE5	24 kV, up to 25 kA, up to 1250 A	3AX14 43-2N
	Width across flats: all	Contact fingers: 26	For 3AE5	7.2/12 kV, up to 31.5 kA, up to 1600 A	3AX14 43-2P
	Width across flats: all	Contact fingers: 26	For 3AE5	17.5 kV, up to 25 kA, up to 1600 A	3AX14 43-2Q
	Width across flats: all	Contact fingers: 13	For 3AE5	7.2/12 kV, up to 31.5 kA, up to 1250 A	3AX14 43-2R
	Width across flats: all	Contact fingers: 13	For 3AE5	17.5 kV, up to 25 kA, up to 1250 A	3AX14 43-2S
	Width across flats: 205 mm	Contact fingers: 26	For 3AE1 (Minis)	7.2/12 kV, up to 31.5 kA, up to 1250 A	3AX14 43-4A
	Width across flats: 310 mm	Contact fingers: 26	For 3AE1 (Minis)	7.2/12 kV, up to 31.5 kA, up to 2500 A	3AX14 43-4B
	Width across flats: 205 mm	Contact fingers: 26	For 3AE1 (Minis)	17.5 kV, up to 31.5 kA, up to 1250 A	3AX14 43-4C
	Width across flats: 310 mm	Contact fingers: 26	For 3AE1 (Minis)	17.5 kV, up to 31.5 kA, up to 2500 A	3AX14 43-4D
	Width across flats: 310 mm	Contact fingers: 26	For 3AE1 (Minis)	7.2/12 kV, up to 31.5 kA, up to 1250 A	3AX14 43-4T
	Width across flats: 310 mm	Contact fingers: 26	For 3AE1 (Minis)	17.5 kV, up to 31.5 kA, up to 1250 A	3AX14 43-4U
	Width across flats: 310 mm	Contact fingers: 26	For 3AE1 (Minis)	7.2/12 kV, 40 kA, up to 1250 A	3AX14 43-4G
	Width across flats: 310 mm	Contact fingers: 26	For 3AE1 (Minis)	7.2/12 kV, 40 kA, up to 3150 A	3AX14 43-4H
	Width across flats: 310 mm	Contact fingers: 26	For 3AE1 (Minis)	17.5 kV, 40 kA, up to 1250 A	3AX14 43-4J
	Width across flats: 310 mm	Contact fingers: 26	For 3AE1 (Minis)	17.5 kV, 40 kA, up to 3150 A	3AX14 43-4K
	Width across flats: 205 mm	Contact fingers: 13	For 3AE1 (Minis)	7.2/12 kV, up to 31.5 kA, up to 1250 A	3AX14 43-4L
Width across flats: 205 mm	Contact fingers: 13	For 3AE1 (Minis)	17.5 kV, up to 31.5 kA, up to 1250 A	3AX14 43-4M	

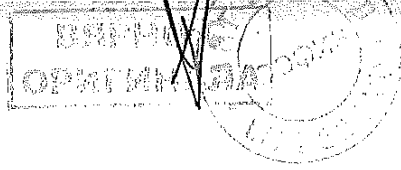

0000321

Device selection

Accessories and spare parts

SION Vacuum Circuit Breakers 3AE5 and 3AE1

			Position:	1 – 9
Designation	Description	Feature	Article No.	
Contact arm, complete with contact system (continued)	Width across flats: 310 mm Contact fingers: 13 For 3AE1 (Minis)	7.2/12 kV, up to 31.5 kA, up to 1250 A	3AX14 43-4V	
	Width across flats: 310 mm Contact fingers: 13 For 3AE1 (Minis)	17.5 kV, up to 31.5 kA, up to 1250 A	3AX14 43-4W	
	Width across flats: 205 mm Contact fingers: 26 For 3AE5 (Minis)	7.2/12 kV, up to 31.5 kA, up to 1250 A	3AX14 43-5A	
	Width across flats: 205 mm Contact fingers: 26 For 3AE5 (Minis)	17.5 kV, up to 25 kA, up to 1250 A	3AX14 43-5B	
	Width across flats: 205 mm Contact fingers: 13 For 3AE5 (Minis)	7.2/12 kV, up to 31.5 kA, up to 1250 A	3AX14 43-5C	
	Width across flats: 205 mm Contact fingers: 13 For 3AE5 (Minis)	17.5 kV, up to 25 kA, up to 1250 A	3AX14 43-5D	
	Width across flats: 310 mm Contact fingers: 26 For 3AE5 (Minis)	7.2/12 kV, up to 31.5 kA, up to 1600 A	3AX14 43-5G	
	Width across flats: 310 mm Contact fingers: 26 For 3AE5 (Minis)	17.5 kV, up to 25 kA, up to 1600 A	3AX14 43-5H	
	Width across flats: 310 mm Contact fingers: 13 For 3AE5 (Minis)	7.2/12 kV, up to 31.5 kA, up to 1600 A	3AX14 43-5J	
Fixed contact	For 3AE1 and 3AE5	7.2/12/17.5 kV, up to 31.5 kA, up to 1250 A	3AX14 44-2A	
	For 3AE1 and 3AE5	7.2/12/17.5 kV, up to 31.5 kA, up to 2500 A 7.2/12/17.5 kV, 40 kA, up to 3150 A	3AX14 44-2B	
	For 3AE1 and 3AE5	7.2/12/17.5 kV, 40 kA, up to 3150 A (Minis)	3AX14 44-2D	
	For 3AE1 and 3AE5	24 kV, up to 25 kA, up to 2500 A	3AX14 44-2C	
Conductor bars (1 set each) for earthing switch connection	For 3AE1 and 3AE5			
	150/210 mm pole-center distance, 275 mm width across flats	7.2/12/17.5 kV, up to 31.5 kA, up to 1250 A	3AX14 55-2A	
	150 mm pole-center distance, 310 mm width across flats	7.2/12/17.5 kV, up to 31.5 kA, up to 1250 A	3AX14 55-2A	
	210 mm pole-center distance, 310 mm width across flats	7.2/12/17.5 kV, up to 31.5 kA, up to 1250 A	3AX14 55-2B	
	210 mm pole-center distance, 310 mm width across flats	7.2/12/17.5 kV, up to 31.5 kA, up to 2500 A	3AX14 55-2C	
	210 mm pole-center distance, 310 mm width across flats	7.2/12/17.5 kV, 40 kA, up to 3150 A	3AX14 55-2D	
	210 mm pole-center distance, 310 mm width across flats	24 kV, up to 25 kA, up to 2150 A	3AX14 55-2E	
	275 mm pole-center distance, 310 mm width across flats	24 kV, up to 25 kA, up to 2150 A	3AX14 55-2F	
Metal protection plate (IP plate)	150 mm pole-center distance and $I_{sc} \leq 25$ kA	For 3AE5	3AX14 56-0A	
	160 mm pole-center distance and $I_{sc} \leq 25$ kA	For 3AE5	3AX14 56-0B	
	210 mm pole-center distance	For 3AE5	3AX14 56-0C	
	275 mm pole-center distance	For 3AE5	3AX14 56-0D	
	150 mm pole-center distance and $I_{sc} = 31.5$ kA	For 3AE5	3AX14 56-1A	
	160 mm pole-center distance and $I_{sc} = 31.5$ kA	For 3AE5	3AX14 56-1B	
Shaft cover	150/160 mm pole-center distance	For 3AE5	3AX14 66-0A	
	150 mm pole-center distance (Ritter)	For 3AE5	3AX14 66-0C	
	210 mm pole-center distance	For 3AE5	3AX14 66-0B	
	275 mm pole-center distance	For 3AE5	3AX14 66-0D	
PG cable gland		For 3AE1 and 3AE5	3AX14 58-0A	
Protection against condensed water	Anti-condensation heating for 230 V AC, 50 W	For 3AE1	3AX14 57-3A	
	Anti-condensation heating for 110 V AC, 50 W	For 3AE1	3AX14 57-3B	
	Anti-condensation heating for 230 V AC, 50 W	For 3AE5	3AX14 57-5A	
	Anti-condensation heating for 110 V AC, 50 W	For 3AE5	3AX14 57-5B	

Designation	Description					Travel/ feature	Position:	1 - 9		10
	Rated voltage for 50/60 Hz U_n kV	Rated short-circuit-breaking current with 36% DC component I_{sc} kA	Pole-center distance mm	Width across flats mm	Rated normal current I_n A		Article No.	Language code *		
Withdrawable part	17.5		150/160			180/without cable harness	3AX71 12-2E			
	17.5		150/160			180/with cable harness for 3AE1	3AX71 12-3E			
	17.5		150/160			180/with cable harness for 3AE5	3AX71 12-4E			
	17.5		150/160			200 / without cable harness	3AX71 12-2G			
	17.5		150/160			200 / with cable harness for 3AE1	3AX71 12-3G			
	17.5		150/160			200 / with cable harness for 3AE5	3AX71 12-4G			
	17.5		150/160			220/without cable harness	3AX71 12-2A			
	17.5		150/160			220/with cable harness for 3AE1	3AX71 12-3A			
	17.5		150/160			220/with cable harness for 3AE5	3AX71 12-4A			
	17.5		200			200 / without cable harness	3AX71 12-2H			
	17.5		200			200 / with cable harness for 3AE1	3AX71 12-3H			
	17.5		210			180/without cable harness	3AX71 12-2F			
	17.5		210			180/with cable harness for 3AE1	3AX71 12-3F			
	17.5		210			180/with cable harness for 3AE5	3AX71 12-4F			
	17.5		210			200 / with cable harness for 3AE5	3AX71 12-4H			
	17.5		210			220/without cable harness	3AX71 12-2B			
	17.5		210			220/with cable harness for 3AE1	3AX71 12-3B			
	17.5		210			220/with cable harness for 3AE5	3AX71 12-4B			
	24		210			260/without cable harness	3AX71 12-2C			
	24		210			260/with cable harness for 3AE1	3AX71 12-3C			
	24		210			260 / with cable harness for 3AE5	3AX71 12-4C			
	24		275			260/without cable harness	3AX71 12-2D			
	24		275			260/with cable harness for 3AE1	3AX71 12-3D			
	24		275			260 / with cable harness for 3AE5	3AX71 12-4D			
Cartridge without earthing switch	17.5	31.5	150	275	1250		3AX71 11-5A			
	17.5	31.5	150	310	1250		3AX71 11-5B			
	17.5	31.5	210	275	1250		3AX71 11-5C			
	17.5	31.5	210	310	1250		3AX71 11-5D			
	17.5	31.5	210	310	> 1250		3AX71 11-5G			
	17.5	40	210	310	All I_n		3AX71 11-5H			
	24	25	210	310	1250		3AX71 11-5E			
	24	25	275	310	1250		3AX71 11-5F			
	24	25	210	310	> 1250		3AX71 11-5J			
24	25	275	310	> 1250		3AX71 11-5K				

2

Handwritten signature

Handwritten signature



Handwritten signature

2

Designation	Description					Travel/feature	Position:	
	Rated voltage U_n for 50/60 Hz kV	Rated short-circuit breaking current with 36% DC component I_{sc} kA	Pole-center distance mm	Width across flats mm	Rated normal current I_n A		1 - 9 Article No.	10 Language code *
Cartridge with earthing switch	17.5	31.5	150	275	1250	with partition	3AX71 11-6A	■
	17.5	31.5	150	310	1250	with partition	3AX71 11-6B	■
	17.5	31.5	210	275	1250	without partition	3AX71 11-6C	■
	17.5	31.5	210	310	1250	without partition	3AX71 11-6D	■
	17.5	31.5	210	310	> 1250	without partition	3AX71 11-6G	■
	17.5	40	210	310	All I_n	without partition	3AX71 11-6H	■
	24	25	210	310	1250	with partition	3AX71 11-6E	■
	24	25	275	310	1250	with partition	3AX71 11-6J	■
	24	25	210	310	> 1250	without partition	3AX71 11-6F	■
	24	25	275	310	> 1250	without partition	3AX71 11-6K	■

*) The language of the rating plate is stated in the table. The individual code has to be added to the article number.

- A German
- B English
- C French
- D Spanish
- E Italian
- F Russian
- G Portuguese
- H Polish
- Z Open with Z = ...



Contents Page

Technical data 49

Electrical data, dimensions and masses

Voltage level 7.2 kV	50
Operating cycle diagrams for 7.2 kV	53
Voltage level 12 kV	54
Operating cycle diagrams for 12 kV	58
Voltage level 17.5 kV	59
Operating cycle diagrams for 17.5 kV	62
Voltage level 24 kV	63
Operating cycle diagrams for 24 kV	65

Dimension drawings

Voltage level 7.2 to 24 kV	66
----------------------------	----

Operating times and internal times	74
------------------------------------	----

Short-circuit protection of motors	74
------------------------------------	----

Consumption data of releases	74
------------------------------	----

Circuit diagrams

Circuit diagrams for 3AE5 and 3AE1	76
------------------------------------	----

3

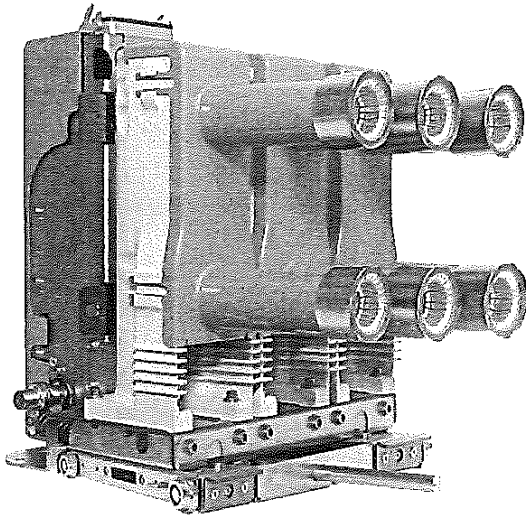

SION vacuum circuit breaker on withdrawable part, with contacts

R-HG11-390.UF

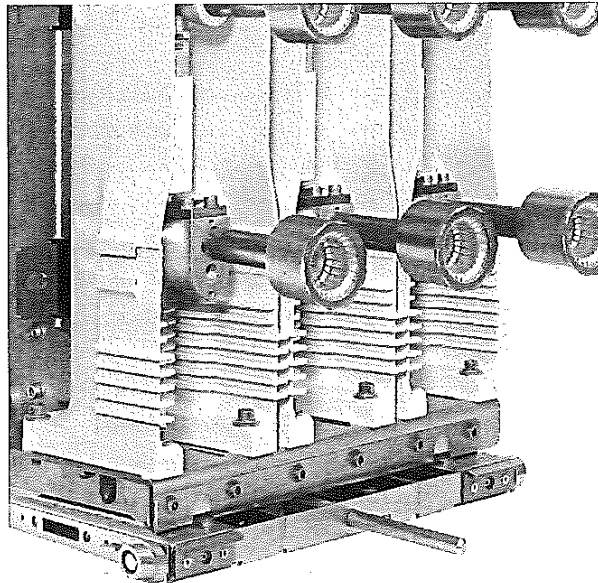

SION vacuum circuit breaker on withdrawable part, with contacts

R-HG11-375.UF

Handwritten signatures and marks.

ВЪРХО СЪ
ОРЪЖИНАТА

СЪДИЩО
2008

СИЕМС БЕЛГИЯ

Siemens HG 11.02 · 2018 47

000034

Technical data

SION Vacuum Circuit Breakers 3AE5 and 3AE1

Electrical data, dimensions and masses for 3AE5

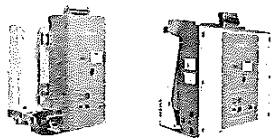

Article No.	7.2 kV 50/60 Hz		Rated normal current I_n A	Width across flats mm	Pole-center distance mm	Rated switching sequence: O - 0.3 s - CO - 15 s - CO	Rated short-circuit duration t_k s	Rated short-circuit breaking current I_{sc} kA	DC component in % of the rated short-circuit breaking current	Asymmetric breaking current kA	Rated short-circuit making current (at 50/60 Hz) I_{ma} kA	Rated back-to-back-capacitor-bank inrush making current I_{bi} kA peak	Rated lightning impulse voltage U_p kV	Rated short-duration power-frequency with- stand voltage U_d kV	Voltage drop ΔU between connections (acc. to IEC 62271-1) at 100 A (DC) mV	Minimum creepage distance interrupters mm	Minimum creepage distance Phase-to-earth mm	Minimum clearance Phase-to-phase mm	Minimum clearance Phase-to-earth mm	Mass ¹⁾ (fixed-mounted circuit breaker/withdrawable module) kg	Detailed dimension drawing (must be explicitly requested)	Operating cycle diagram no. (see page 58)					
	3AE5 002-1...	3AE5 002-2...																					3AE5 003-1...	3AE5 003-2...	3AE5 004-1...	3AE5 004-2...	3AE5 005-1...
3AE5 002-1...	800	205	150	■	3	16	50	17.9	40/42	▲	60	20	3	93	245	93	97	49/-	A7E44202010	1							
3AE5 002-2...	1250	205	150	■	3	16	50	17.9	40/42	▲	60	20	3	93	245	93	97	49/-	A7E44202010	1							
3AE5 003-1...	800	205	150	■	3	20	50	22.4	50/52	▲	60	20	3	93	245	93	97	49/-	A7E44202010	2							
3AE5 003-2...	1250	205	150	■	3	20	50	22.4	50/52	▲	60	20	3	93	245	93	97	49/-	A7E44202010	2							
3AE5 004-1...	800	205	150	■	3	25	50	28	63/65	▲	60	20	3	93	245	93	97	49/-	A7E44202010	3a							
3AE5 004-2...	1250	205	150	■	3	25	50	28	63/65	▲	60	20	3	93	245	93	97	49/-	A7E44202010	3a							
3AE5 005-1...	800	205	150	■	3	31.5	50	35.4	80/82	20	60	20	2.5	90	255	98	97	53.5/-	A7E44202010	4a							
3AE5 005-2...	1250	205	150	■	3	31.5	50	35.4	80/82	20	60	20	2.5	90	255	98	97	53.5/-	A7E44202010	4a							
3AE5 012-1...	800	275	150	■	3	16	50	17.9	40/42	▲	60	20	3	93	245	93	97	49/85	A7E44202011	1							
3AE5 012-2...	1250	275	150	■	3	16	50	17.9	40/42	▲	60	20	3	93	245	93	97	49/85	A7E44202011	1							
3AE5 013-1...	800	275	150	■	3	20	50	22.4	50/52	▲	60	20	3	93	245	93	97	49/85	A7E44202011	2							
3AE5 013-2...	1250	275	150	■	3	20	50	22.4	50/52	▲	60	20	3	93	245	93	97	49/85	A7E44202011	2							
3AE5 014-1...	800	275	150	■	3	25	50	28	63/65	▲	60	20	3	93	245	93	97	49/85	A7E44202011	3a							
3AE5 014-2...	1250	275	150	■	3	25	50	28	63/65	▲	60	20	3	93	245	93	97	49/85	A7E44202011	3a							
3AE5 015-1...	800	275	150	■	3	31.5	50	35.4	80/82	20	60	20	2.5	90	255	98	122	53.5/89.5	A7E44202011	4a							
3AE5 015-2...	1250	275	150	■	3	31.5	50	35.4	80/82	20	60	20	2.5	90	255	98	122	53.5/89.5	A7E44202011	4a							
3AE5 022-1...	800	310	150	■	3	16	50	17.9	40/42	▲	60	20	3	93	245	93	97	49/85	A7E44202012	1							
3AE5 022-2...	1250	310	150	■	3	16	50	17.9	40/42	▲	60	20	3	93	245	93	97	49/85	A7E44202012	1							
3AE5 022-3...	1600	310	150	■	3	16	50	17.9	40/42	20	60	20	2.5	90	255	98	122	59.5/95.5	A7E44202011	1a							
3AE5 023-1...	800	310	150	■	3	20	50	22.4	50/52	▲	60	20	3	93	245	93	97	49/85	A7E44202012	2							
3AE5 023-2...	1250	310	150	■	3	20	50	22.4	50/52	▲	60	20	3	93	245	93	97	49/85	A7E44202012	2							
3AE5 023-3...	1600	310	150	■	3	20	50	22.4	50/52	20	60	20	2.5	90	255	98	122	59.5/95.5	A7E44202012	2a							
3AE5 024-1...	800	310	150	■	3	25	50	28	63/65	▲	60	20	3	93	245	93	97	49/85	A7E44202012	3a							
3AE5 024-2...	1250	310	150	■	3	25	50	28	63/65	▲	60	20	3	93	245	93	97	49/85	A7E44202012	3a							
3AE5 024-3...	1600	310	150	■	3	25	50	28	63/65	20	60	20	2.5	90	255	98	122	59.5/95.5	A7E44202012	3b							
3AE5 025-1...	800	310	150	■	3	31.5	50	35.4	80/82	20	60	20	2.5	90	255	98	122	53.5/89.5	A7E44202012	4a							
3AE5 025-2...	1250	310	150	■	3	31.5	50	35.4	80/82	20	60	20	2.5	90	255	98	122	53.5/89.5	A7E44202012	4a							
3AE5 025-3...	1600	310	150	■	3	31.5	50	35.4	80/82	20	60	20	2.5	90	255	98	122	59.5/95.5	A7E44202012	4a							

▲ On request

■ Standard information on rating plate

1) The mass of the fixed-mounted circuit breaker, fitted on the withdrawable part, increases by the values specified in the dimension drawing of the withdrawable part (page 83)

Note: Dimension drawings from page 79

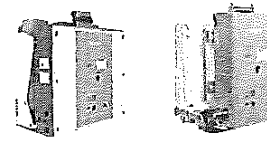

Article No.	7.2 kV 50/60 Hz		Rated normal current	Width across flats	Pole-center distance	Rated switching sequence: O - 0.3 s - CO - 15 s - CO	Rated short-circuit duration	Rated short-circuit breaking current	DC component in % of the rated short-circuit breaking current	Asymmetric breaking current	Rated short-circuit making current (at 50/60 Hz)	Rated back-to-back-capacitor-bank inrush making current	Rated lightning impulse voltage	Rated short-duration power-frequency with- stand voltage	Voltage drop ΔU between connections (acc. to IEC 62271-1) at 100 A DC	Minimum creepage distance Interrupters	Minimum creepage distance Phase-to-earth	Minimum clearance Phase-to-phase	Minimum clearance Phase-to-earth	Mass ¹⁾ (fixed-mounted circuit breaker/withdrawable module)	Detailed dimension drawing (must be explicitly requested)	Operating cycle diagram no. (see page 58)
	I_n	A	mm	mm	s	kA	%	kA	kA	I_{ms}	I_{bi} kA peak	U_p kV	U_d kV	mV	mm	mm	mm	mm	mm	kg		
3AE5 032-1...	800	205	160	■	3	16	50	17.9	40/42	▲	60	20	3	93	245	93	129	49/-	A7E44202016	1		
3AE5 032-2...	1250	205	160	■	3	16	50	17.9	40/42	▲	60	20	3	93	245	93	129	49/-	A7E44202016	1		
3AE5 033-1...	800	205	160	■	3	20	50	22.4	50/52	▲	60	20	3	93	245	93	129	49/-	A7E44202016	2		
3AE5 033-2...	1250	205	160	■	3	20	50	22.4	50/52	▲	60	20	3	93	245	93	129	49/-	A7E44202016	2		
3AE5 034-1...	800	205	160	■	3	25	50	28	63/65	▲	60	20	3	93	245	93	129	49/-	A7E44202016	3a		
3AE5 034-2...	1250	205	160	■	3	25	50	28	63/65	▲	60	20	3	93	245	93	129	49/-	A7E44202016	3a		
3AE5 035-1...	800	205	160	■	3	31.5	50	35.4	80/82	20	60	20	2.5	90	255	98	122	53.5/-	A7E44202016	4a		
3AE5 035-2...	1250	205	160	■	3	31.5	50	35.4	80/82	20	60	20	2.5	90	255	98	122	53.5/-	A7E44202016	4a		
3AE5 042-1...	800	275	160	■	3	16	50	17.9	40/42	▲	60	20	3	93	245	93	129	49/-	A7E44202017	1		
3AE5 042-2...	1250	275	160	■	3	16	50	17.9	40/42	▲	60	20	3	93	245	93	129	49/-	A7E44202017	1		
3AE5 043-1...	800	275	160	■	3	20	50	22.4	50/52	▲	60	20	3	93	245	93	129	49/-	A7E44202017	2		
3AE5 043-2...	1250	275	160	■	3	20	50	22.4	50/52	▲	60	20	3	93	245	93	129	49/-	A7E44202017	2		
3AE5 044-1...	800	275	160	■	3	25	50	28	63/65	▲	60	20	3	93	245	93	129	49/-	A7E44202017	3a		
3AE5 044-2...	1250	275	160	■	3	25	50	28	63/65	▲	60	20	3	93	245	93	129	49/-	A7E44202017	3a		
3AE5 045-1...	800	275	160	■	3	31.5	50	35.4	80/82	20	60	20	2.5	90	255	98	122	53.5/-	A7E44202017	4a		
3AE5 045-2...	1250	275	160	■	3	31.5	50	35.4	80/82	20	60	20	2.5	90	255	98	122	53.5/-	A7E44202017	4a		
3AE5 052-1...	800	310	160	■	3	16	50	17.9	40/42	▲	60	20	3	93	245	93	129	49/-	A7E44202018	1		
3AE5 052-2...	1250	310	160	■	3	16	50	17.9	40/42	▲	60	20	3	93	245	93	129	49/-	A7E44202018	1		
3AE5 052-3...	1600	310	160	■	3	16	50	17.9	40/42	20	60	20	2.5	90	255	98	122	59.5/-	A7E44202018	1a		
3AE5 053-1...	800	310	160	■	3	20	50	22.4	50/52	▲	60	20	3	93	245	93	129	49/-	A7E44202018	2		
3AE5 053-2...	1250	310	160	■	3	20	50	22.4	50/52	▲	60	20	3	93	245	93	129	49/-	A7E44202018	2		
3AE5 053-3...	1600	310	160	■	3	20	50	22.4	50/52	20	60	20	2.5	90	255	98	122	59.5/-	A7E44202018	2a		
3AE5 054-1...	800	310	160	■	3	25	50	28	63/65	▲	60	20	3	93	245	93	129	49/-	A7E44202018	3a		
3AE5 054-2...	1250	310	160	■	3	25	50	28	63/65	▲	60	20	3	93	245	93	129	49/-	A7E44202018	3a		
3AE5 054-3...	1600	310	160	■	3	25	50	28	63/65	20	60	20	2.5	90	255	98	122	59.5/-	A7E44202018	3b		
3AE5 055-1...	800	310	160	■	3	31.5	50	35.4	80/82	20	60	20	2.5	90	255	98	122	53.5/-	A7E44202018	4a		
3AE5 055-2...	1250	310	160	■	3	31.5	50	35.4	80/82	20	60	20	2.5	90	255	98	122	53.5/-	A7E44202018	4a		
3AE5 055-3...	1600	310	160	■	3	31.5	50	35.4	80/82	20	60	20	2.5	90	255	98	122	59.5/-	A7E44202018	4a		

▲ On request

■ Standard information on rating plate

1) The mass of the fixed-mounted circuit breaker, fitted on the withdrawable part, increases by the values specified in the dimension drawing of the withdrawable part (page 83)

3

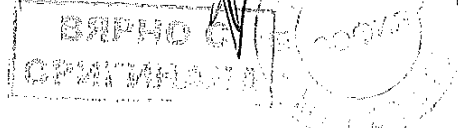

Technical data

SION Vacuum Circuit Breakers 3AE5 and 3AE1

Electrical data, dimensions and masses for 3AE5

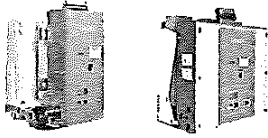

Article No.	7.2 kV 50/60 Hz		Rated normal current I_n A	Width across flats mm	Pole-center distance mm	Rated switching sequence: O – 0.3 s – CO – 15 s – CO	Rated short-circuit duration t_k s	Rated short-circuit breaking current I_{kR} kA	DC component in % of the rated short-circuit breaking current	Asymmetric breaking current kA	Rated short-circuit making current (at 50/60 Hz) I_{mi} kA	Rated back-to-back-capacitor-bank inrush making current I_{bi} kA peak	Rated lightning impulse voltage U_p kV	Rated short-duration power-frequency with- stand voltage U_d kV	Voltage drop ΔU between connections (acc. to IEC 62271-1) at 100 A DC mV	Minimum creepage distance Interrupters mm	Minimum creepage distance Phase-to-earth mm	Minimum clearance Phase-to-phase mm	Minimum clearance Phase-to-earth mm	Mass ¹⁾ (fixed-mounted circuit breaker/withdrawable module) kg	Detailed dimension drawing (must be explicitly requested)	Operating cycle diagram no. (see page 58)
	mm	mm																				
3AE5 062-1...	800	205	210	■	3	16	50	17.9	40/42	▲	60	20	3	93	245	93	129	51.5/91.5	A7E44202022	1		
3AE5 062-2...	1250	205	210	■	3	16	50	17.9	40/42	▲	60	20	3	93	245	93	129	51.5/91.5	A7E44202022	1		
3AE5 063-1...	800	205	210	■	3	20	50	22.4	50/52	▲	60	20	3	93	245	93	129	51.5/-	A7E44202022	2		
3AE5 063-2...	1250	205	210	■	3	20	50	22.4	50/52	▲	60	20	3	93	245	93	129	51.5/-	A7E44202022	2		
3AE5 064-1...	800	205	210	■	3	25	50	28	63/65	▲	60	20	3	93	245	93	129	51.5/-	A7E44202022	3a		
3AE5 064-2...	1250	205	210	■	3	25	50	28	63/65	▲	60	20	3	93	245	93	129	51.5/-	A7E44202022	3a		
3AE5 065-1...	800	205	210	■	3	31.5	50	35.4	80/82	20	60	20	2.5	90	255	98	122	56.5/-	A7E44202022	4a		
3AE5 065-2...	1250	205	210	■	3	31.5	50	35.4	80/82	20	60	20	2.5	90	255	98	122	56.5/-	A7E44202022	4a		
3AE5 072-1...	800	275	210	■	3	16	50	17.9	40/42	▲	60	20	3	93	245	93	129	51.5/91.5	A7E44202023	1		
3AE5 072-2...	1250	275	210	■	3	16	50	17.9	40/42	▲	60	20	3	93	245	93	129	51.5/91.5	A7E44202023	1		
3AE5 073-1...	800	275	210	■	3	20	50	22.4	50/52	▲	60	20	3	93	245	93	129	51.5/91.5	A7E44202023	2		
3AE5 073-2...	1250	275	210	■	3	20	50	22.4	50/52	▲	60	20	3	93	245	93	129	51.5/91.5	A7E44202023	2		
3AE5 074-1...	800	275	210	■	3	25	50	28	63/65	▲	60	20	3	93	245	93	129	51.5/91.5	A7E44202023	3a		
3AE5 074-2...	1250	275	210	■	3	25	50	28	63/65	▲	60	20	3	93	245	93	129	51.5/91.5	A7E44202023	3a		
3AE5 075-1...	800	275	210	■	3	31.5	50	35.4	80/82	20	60	20	2.5	90	255	98	122	56.5/96.5	A7E44202023	4a		
3AE5 075-2...	1250	275	210	■	3	31.5	50	35.4	80/82	20	60	20	2.5	90	255	98	122	56.5/96.5	A7E44202023	4a		
3AE5 082-1...	800	310	210	■	3	16	50	17.9	40/42	▲	60	20	3	93	245	93	129	51.5/91.5	A7E44202024	1		
3AE5 082-2...	1250	310	210	■	3	16	50	17.9	40/42	▲	60	20	3	93	245	93	129	51.5/91.5	A7E44202024	1		
3AE5 082-3...	1600	310	210	■	3	16	50	17.9	40/42	20	60	20	2.5	90	255	98	122	62.5/102.5	A7E44202024	1a		
3AE5 083-1...	800	310	210	■	3	20	50	22.4	50/52	▲	60	20	3	93	245	93	129	51.5/91.5	A7E44202024	2		
3AE5 083-2...	1250	310	210	■	3	20	50	22.4	50/52	▲	60	20	3	93	245	93	129	51.5/91.5	A7E44202024	2		
3AE5 083-3...	1600	310	210	■	3	20	50	22.4	50/52	20	60	20	2.5	90	255	98	122	62.5/102.5	A7E44202024	2a		
3AE5 084-1...	800	310	210	■	3	25	50	28	63/65	▲	60	20	3	93	245	93	129	51.5/91.5	A7E44202024	3a		
3AE5 084-2...	1250	310	210	■	3	25	50	28	63/65	▲	60	20	3	93	245	93	129	51.5/91.5	A7E44202024	3a		
3AE5 084-3...	1600	310	210	■	3	25	50	28	63/65	20	60	20	2.5	90	255	98	122	62.5/102.5	A7E44202024	3b		
3AE5 084-4...	2000	310	210	■	3	25	50	30.6	63/65	20	60	20	1.8	130	240	125	138	100	A7E10907000	3c		
3AE5 084-6...	2500	310	210	■	3	25	50	30.6	63/65	20	60	20	1.8	130	240	125	138	100	A7E10907000	3c		
3AE5 085-1...	800	310	210	■	3	31.5	50	35.4	80/82	20	60	20	2.5	90	255	98	122	56.5/96.5	A7E44202024	4a		

▲ On request

■ Standard information on rating plate

1) The mass of the fixed-mounted circuit breaker, fitted on the withdrawable part, increases by the values specified in the dimension drawing of the withdrawable part (page 83)



Article No.	7.2 kV 50/60 Hz		Rated normal current	Width across flats	Pole-center distance	Rated switching sequence: O - 0.3 s - CO - 15 s - CO	Rated short-circuit duration	Rated short-circuit breaking current	DC component in % of the rated short-circuit breaking current	Asymmetric breaking current	Rated short-circuit making current (at 50/60 Hz)	Rated back-to-back-capacitor-bank inrush making current	Rated lightning impulse voltage	Rated short-duration power-frequency with- stand voltage	Voltage drop ΔU between connections (acc. to IEC 62271-1 at 100 A DC)	Minimum creepage distance Interrupters	Minimum creepage distance Phase-to-earth	Minimum clearance Phase-to-phase	Minimum clearance Phase-to-earth	Mass 1) (fixed-mounted circuit breaker/withdrawable module)	Detailed dimension drawing (must be explicitly requested)	Operating cycle diagram no. (see page 58)
	I_n	A	mm	mm	s	kA	%	kA	kA	kA	I_{ma}	I_{bi} peak	U_p	U_d	mV	mm	mm	mm	mm	kg		
3AE5 085-2...	1250	310	210	■	3	31.5	50	35.4	80/82	20	60	20	2.5	90	255	98	122	56.5/96.5	A7E44202024	4a		
3AE5 085-3...	1600	310	210	■	3	31.5	50	35.4	80/82	20	60	20	2.5	90	255	98	122	62.5/102.5	A7E44202024	4a		
3AE5 085-4...	2000	310	210	■	3	31.5	50	38.5	80/82	20	60	20	1.8	130	240	125	138	100	A7E10907000	4b		
3AE5 085-6...	2500	310	210	■	3	31.5	50	38.5	80/82	20	60	20	1.8	130	240	125	138	100	A7E10907000	4b		
3AE1 086-2...	1250	310	210	■	3	40	36	44.9	100/104	10	60	20	1.7	145	155	169	140	120/160	A7E44202070	5		
3AE1 086-4...	2000	310	210	■	3	40	36	44.9	100/104	10	60	20	1.0	145	249	149	140	160/210	A7E44202071	5		
3AE1 086-6...	2500	310	210	■	3	40	36	44.9	100/104	10	60	20	1.0	145	249	149	140	160/210	A7E44202071	5		
3AE1 086-7...	3150	310	210	■	3	40	36	44.9	100/104	10	60	20	1.0	145	249	149	140	160/210	A7E44202071	5		

▲ On request

■ Standard information on rating plate

1) The mass of the fixed-mounted circuit breaker, fitted on the withdrawable part, increases by the values specified in the dimension drawing of the withdrawable part (page 83)

Note: Dimension drawings from page 79

3

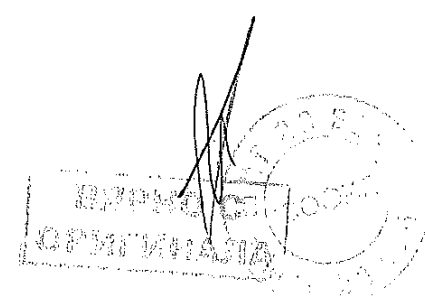

Technical data

SION Vacuum Circuit Breakers 3AE5 and 3AE1

Electrical data, dimensions and masses for 3AE1

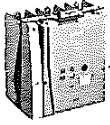

Operating cycle diagrams for 7.2 kV

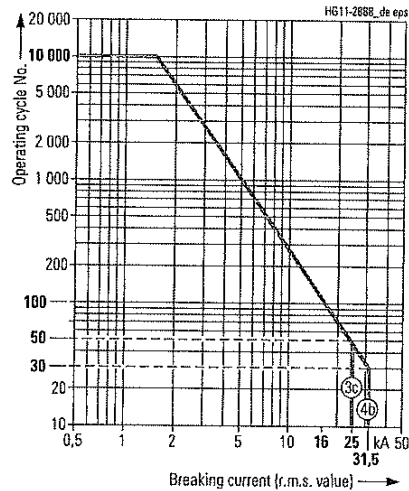
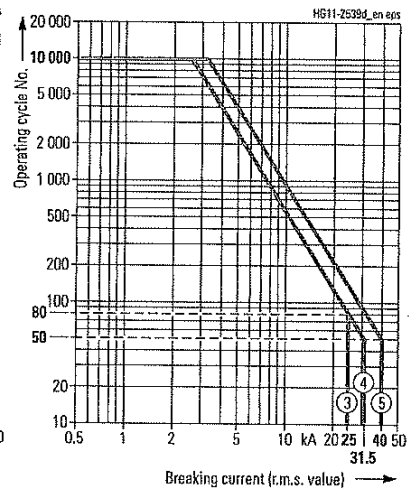
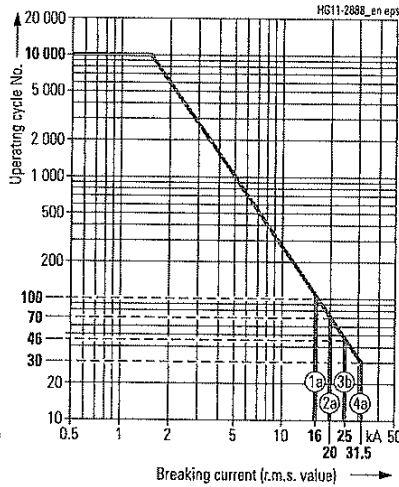
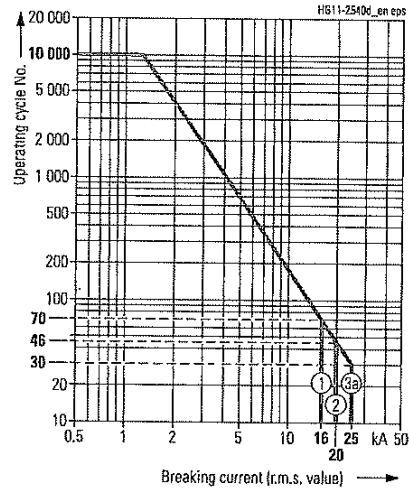

The permissible number of electrical operating cycles is shown as a function of the breaking current (r.m.s. value). All SION vacuum circuit breakers fulfill the endurance classes E2, M2 and C2 according to IEC 62271-100. The curve shape beyond the parameters defined in IEC 62271-100 is based on average usage data. The number of operating cycles that can actually be reached can be different depending on the respective application.

3

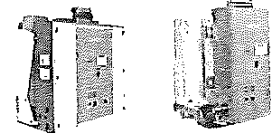

Article No.	12 kV 50/60 Hz		Rated normal current I_n A	Width across flats mm	Pole-center distance mm	Rated switching sequence: O - 0.3 s - CO - 15 s - CO	Rated short-circuit duration t_p s	Rated short-circuit breaking current I_{sc} kA	DC component in % of the rated short-circuit breaking current	Asymmetric breaking current kA	Rated short-circuit making current (at 50/60 Hz) I_m kA	Rated back-to-back-capacitor-bank inrush making current I_{bi} kA peak	Rated lightning impulse voltage U_p kV	Rated short-circuit power-frequency-with- stand voltage U_d kV	Voltage drop ΔU between connections (acc. to IEC 62271-1 at 100 A DC) mV	Minimum creepage distance Interrupters mm	Minimum creepage distance Phase-to-earth mm	Minimum clearance Phase-to-phase mm	Minimum clearance Phase-to-earth mm	Mass ¹⁾ fixed-mounted circuit breaker/withdrawable module kg	Detailed dimension drawing (must be explicitly requested)	Operating cycle diagram no. (see page 67)
	Rated normal current	Width across flats																				
3AE5 102-1...	800	205	150	■	3	16	50	17.9	40/42	▲	75	28	3	93	245	93	129	49/-	A7E44202010	6		
3AE5 102-2...	1250	205	150	■	3	16	50	17.9	40/42	▲	75	28	3	93	245	93	129	49/-	A7E44202010	6		
3AE5 103-1...	800	205	150	■	3	20	50	22.4	50/52	▲	75	28	3	93	245	93	129	49/-	A7E44202010	7		
3AE5 103-2...	1250	205	150	■	3	20	50	22.4	50/52	▲	75	28	3	93	245	93	129	49/-	A7E44202010	7		
3AE5 104-1...	800	205	150	■	3	25	50	28	63/65	▲	75	28	3	93	245	93	129	49/-	A7E44202010	8a		
3AE5 104-2...	1250	205	150	■	3	25	50	28	63/65	▲	75	28	3	93	245	93	129	49/-	A7E44202010	8a		
3AE5 105-1...	800	205	150	■	3	31.5	50	35.4	80/82	20	75	28	2.5	90	255	98	122	53.5/-	A7E44202010	9a		
3AE5 105-2...	1250	205	150	■	3	31.5	50	35.4	80/82	20	75	28	2.5	90	255	98	122	53.5/-	A7E44202010	9a		
3AE5 112-1...	800	275	150	■	3	16	50	17.9	40/42	▲	75	28	3	93	245	93	129	49/85	A7E44202011	6		
3AE5 112-2...	1250	275	150	■	3	16	50	17.9	40/42	▲	75	28	3	93	245	93	129	49/85	A7E44202011	6		
3AE5 113-1...	800	275	150	■	3	20	50	22.4	50/52	▲	75	28	3	93	245	93	129	49/85	A7E44202011	7		
3AE5 113-2...	1250	275	150	■	3	20	50	22.4	50/52	▲	75	28	3	93	245	93	129	49/85	A7E44202011	7		
3AE5 114-1...	800	275	150	■	3	25	50	28	63/65	▲	75	28	3	93	245	93	129	49/85	A7E44202011	8a		
3AE5 114-2...	1250	275	150	■	3	25	50	28	63/65	▲	75	28	3	93	245	93	129	49/85	A7E44202011	8a		
3AE5 115-1...	800	275	150	■	3	31.5	50	35.4	80/82	20	75	28	2.5	90	255	98	122	53.5/89.5	A7E44202011	9a		
3AE5 115-2...	1250	275	150	■	3	31.5	50	35.4	80/82	20	75	28	2.5	90	255	98	122	53.5/89.5	A7E44202011	9a		
3AE5 122-1...	800	310	150	■	3	16	50	17.9	40/42	▲	75	28	3	93	245	93	129	49/85	A7E44202012	6		
3AE5 122-2...	1250	310	150	■	3	16	50	17.9	40/42	▲	75	28	3	93	245	93	129	49/85	A7E44202012	6		
3AE5 122-3...	1600	310	150	■	3	16	50	17.9	40/42	20	75	28	2.5	90	255	98	122	59.5/89.5	A7E44202012	6a		
3AE5 123-1...	800	310	150	■	3	20	50	22.4	50/52	▲	75	28	3	93	245	93	129	49/85	A7E44202012	7		
3AE5 123-2...	1250	310	150	■	3	20	50	22.4	50/52	▲	75	28	3	93	245	93	129	49/85	A7E44202012	7		
3AE5 123-3...	1600	310	150	■	3	20	50	22.4	50/52	20	75	28	2.5	90	255	98	122	59.5/89.5	A7E44202012	7a		
3AE5 124-1...	800	310	150	■	3	25	50	28	63/65	▲	75	28	3	93	245	93	129	49/85	A7E44202012	8a		
3AE5 124-2...	1250	310	150	■	3	25	50	28	63/65	▲	75	28	3	93	245	93	129	49/85	A7E44202012	8a		
3AE5 124-3...	1600	310	150	■	3	25	50	28	63/65	20	75	28	2.5	90	255	98	122	59.5/89.5	A7E44202012	8b		

▲ On request

■ Standard information on rating plate

1) The mass of the fixed-mounted circuit breaker, fitted on the withdrawable part, increases by the values specified in the dimension drawing of the withdrawable part (page 83)

СИММЕНС
ОПТИМАЛ

3

Technical data

SION Vacuum Circuit Breakers 3AE5 and 3AE1

Electrical data, dimensions and masses for 3AE5

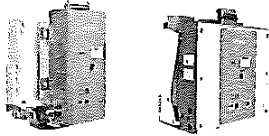

Article No.	12 kV 50/60 Hz		Rated normal current I_n A	Width across flats mm	Pole-center distance mm	Rated switching sequence: O - 0.3 s - CO - 15 s - CO	Rated short-circuit duration t_k s	Rated short-circuit breaking current I_{sc} kA	DC component in % of the rated short-circuit breaking current	Asymmetric breaking current kA	Rated short-circuit making current (at 50/60 Hz) I_{ma} kA	Rated back-to-back-capacitor-bank inrush making current I_{bi} kA peak	Rated lightning impulse voltage U_p kV	Rated short-duration power-frequency with- stand voltage U_d kV	Voltage drop ΔU between connections (acc. to IEC 62271-1) at 100 A DC) mV	Minimum creepage distance interrupters mm	Minimum creepage distance Phase-to-earth mm	Minimum clearance Phase-to-phase mm	Minimum clearance Phase-to-earth mm	Mass ¹⁾ (fixed-mounted circuit breaker/withdrawable module) kg	Detailed dimension drawing (must be explicitly requested)	Operating cycle diagram no. (see page 67)
	■	▲																				
3AE5 125-1...	800	310	150	■	3	31.5	50	35.4	80/82	20	75	28	2.5	90	255	98	122	53.5/89.5	A7E44202012	9a		
3AE5 125-2...	1250	310	150	■	3	31.5	50	35.4	80/82	20	75	28	2.5	90	255	98	122	53.5/89.5	A7E44202012	9a		
3AE5 125-3...	1600	310	150	■	3	31.5	50	35.4	80/82	20	75	28	2.5	90	255	98	122	59.5/95.5	A7E44202012	9a		
3AE5 132-1...	800	205	160	■	3	16	50	17.9	40/42	▲	75	28	3	93	245	93	129	49/-	A7E44202016	6		
3AE5 132-2...	1250	205	160	■	3	16	50	17.9	40/42	▲	75	28	3	93	245	93	129	49/-	A7E44202016	6		
3AE5 133-1...	800	205	160	■	3	20	50	22.4	50/52	▲	75	28	3	93	245	93	129	49/-	A7E44202016	7		
3AE5 133-2...	1250	205	160	■	3	20	50	22.4	50/52	▲	75	28	3	93	245	93	129	49/-	A7E44202016	7		
3AE5 134-1...	800	205	160	■	3	25	50	28	63/65	▲	75	28	3	93	245	93	129	49/-	A7E44202016	8a		
3AE5 134-2...	1250	205	160	■	3	25	50	28	63/65	▲	75	28	3	93	245	93	129	49/-	A7E44202016	8a		
3AE5 135-1...	800	205	160	■	3	31.5	50	35.4	80/82	20	75	28	2.5	90	255	98	122	53.5/-	A7E44202016	9a		
3AE5 135-2...	1250	205	160	■	3	31.5	50	35.4	80/82	20	75	28	2.5	90	255	98	122	53.5/-	A7E44202016	9a		
3AE5 142-1...	800	275	160	■	3	16	50	17.9	40/42	▲	75	28	3	93	245	93	129	49/-	A7E44202017	6		
3AE5 142-2...	1250	275	160	■	3	16	50	17.9	40/42	▲	75	28	3	93	245	93	129	49/-	A7E44202017	6		
3AE5 143-1...	800	275	160	■	3	20	50	22.4	50/52	▲	75	28	3	93	245	93	129	49/-	A7E44202017	7		
3AE5 143-2...	1250	275	160	■	3	20	50	22.4	50/52	▲	75	28	3	93	245	93	129	49/-	A7E44202017	7		
3AE5 144-1...	800	275	160	■	3	25	50	28	63/65	▲	75	28	3	93	245	93	129	49/-	A7E44202017	8a		
3AE5 144-2...	1250	275	160	■	3	25	50	28	63/65	▲	75	28	3	93	245	93	129	49/-	A7E44202017	8a		
3AE5 145-1...	800	275	160	■	3	31.5	50	35.4	80/82	20	75	28	2.5	90	255	98	122	53.5/-	A7E44202017	9a		
3AE5 145-2...	1250	275	160	■	3	31.5	50	35.4	80/82	20	75	28	2.5	90	255	98	122	53.5/-	A7E44202017	9a		
3AE5 152-1...	800	310	160	■	3	16	50	17.9	40/42	▲	75	28	3	93	245	93	129	49/-	A7E44202018	6		
3AE5 152-2...	1250	310	160	■	3	16	50	17.9	40/42	▲	75	28	3	93	245	93	129	49/-	A7E44202018	6		
3AE5 152-3...	1600	310	160	■	3	16	50	17.9	40/42	20	75	28	2.5	90	255	98	122	59.5/-	A7E44202018	6a		
3AE5 153-1...	800	310	160	■	3	20	50	22.4	50/52	▲	75	28	3	93	245	93	129	49/-	A7E44202018	7		
3AE5 153-2...	1250	310	160	■	3	20	50	22.4	50/52	▲	75	28	3	93	245	93	129	49/-	A7E44202018	7		
3AE5 153-3...	1600	310	160	■	3	20	50	22.4	50/52	20	75	28	2.5	90	255	98	122	59.5/-	A7E44202018	7a		

▲ On request

■ Standard information on rating plate

1) The mass of the fixed-mounted circuit breaker, fitted on the withdrawable part, increases by the values specified in the dimension drawing of the withdrawable part (page 83)

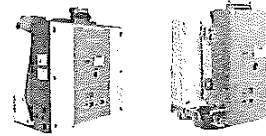

Article No.	12 kV 50/60 Hz		Rated normal current I_n A	Width across flats mm	Pole-center distance mm	Rated switching sequence: O - 0.3 s - CO - 1.5 s - CO	Rated short-circuit duration t_k s	Rated short-circuit breaking current I_{sc} kA	DC component in % of the rated short-circuit breaking current	Asymmetric breaking current kA	Rated short-circuit making current (at 50/60 Hz) I_{ma} kA	Rated back-to-back-capacitor-bank inrush making current I_{bi} kA peak	Rated lightning impulse voltage U_p kV	Rated short-duration power-frequency with- stand voltage U_d kV	Voltage drop ΔU between connections (acc. to IEC 62271-1 at 100 A DC) mV	Minimum creepage distance interrupters mm	Minimum creepage distance Phase-to-earth mm	Minimum clearance Phase-to-phase mm	Minimum clearance Phase-to-earth mm	Mass ¹⁾ (fixed-mounted circuit breaker/withdrawable module) kg	Detailed dimension drawing (must be explicitly requested)	Operating cycle diagram no. (see page 67)
	3	4																				
3AE5 154-1...	800	310	160	■	3	25	50	28	63/65	▲	75	28	3	93	245	93	129	49/-	A7E44202018	8a		
3AE5 154-2...	1250	310	160	■	3	25	50	28	63/65	▲	75	28	3	93	245	93	129	49/-	A7E44202018	8a		
3AE5 154-3...	1600	310	160	■	3	25	50	28	63/65	20	75	28	2.5	90	255	98	122	59.5/-	A7E44202018	8b		
3AE5 155-1...	800	310	160	■	3	31.5	50	35.4	80/82	20	75	28	2.5	90	255	98	122	53.5/-	A7E44202018	9a		
3AE5 155-2...	1250	310	160	■	3	31.5	50	35.4	80/82	20	75	28	2.5	90	255	98	122	53.5/-	A7E44202018	9a		
3AE5 155-3...	1600	310	160	■	3	31.5	50	35.4	80/82	20	75	28	2.5	90	255	98	122	59.5/-	A7E44202018	9a		
3AE5 162-1...	800	205	210	■	3	16	50	17.9	40/42	▲	75	28	3	93	245	93	129	51.5/-	A7E44202022	6		
3AE5 162-2...	1250	205	210	■	3	16	50	17.9	40/42	▲	75	28	3	93	245	93	129	51.5/-	A7E44202022	6		
3AE5 163-1...	800	205	210	■	3	20	50	22.4	50/52	▲	75	28	3	93	245	93	129	51.5/-	A7E44202022	7		
3AE5 163-2...	1250	205	210	■	3	20	50	22.4	50/52	▲	75	28	3	93	245	93	129	51.5/-	A7E44202022	7		
3AE5 164-1...	800	205	210	■	3	25	50	28	63/65	▲	75	28	3	93	245	93	129	49/-	A7E44202022	8a		
3AE5 164-2...	1250	205	210	■	3	25	50	28	63/65	▲	75	28	3	93	245	93	129	49/-	A7E44202022	8a		
3AE5 165-1...	800	205	210	■	3	31.5	50	35.4	80/82	20	75	28	2.5	90	255	98	122	56.5/-	A7E44202022	9a		
3AE5 165-2...	1250	205	210	■	3	31.5	50	35.4	80/82	20	75	28	2.5	90	255	98	122	56.5/-	A7E44202022	9a		
3AE5 172-1...	800	275	210	■	3	16	50	17.9	40/42	▲	75	28	3	93	245	93	129	51.5/1.5	A7E44202023	6		
3AE5 172-2...	1250	275	210	■	3	16	50	17.9	40/42	▲	75	28	3	93	245	93	129	51.5/1.5	A7E44202023	6		
3AE5 173-1...	800	275	210	■	3	20	50	22.4	50/52	▲	75	28	3	93	245	93	129	51.5/1.5	A7E44202023	7		
3AE5 173-2...	1250	275	210	■	3	20	50	22.4	50/52	▲	75	28	3	93	245	93	129	51.5/1.5	A7E44202023	7		
3AE5 174-1...	800	275	210	■	3	25	50	28	63/65	▲	75	28	3	93	245	93	129	51.5/1.5	A7E44202023	8a		
3AE5 174-2...	1250	275	210	■	3	25	50	28	63/65	▲	75	28	3	93	245	93	129	51.5/1.5	A7E44202023	8a		
3AE5 175-1...	800	275	210	■	3	31.5	50	35.4	80/82	20	75	28	2.5	90	255	98	122	56.5/6.5	A7E44202023	9a		
3AE5 175-2...	1250	275	210	■	3	31.5	50	35.4	80/82	20	75	28	2.5	90	255	98	122	56.5/6.5	A7E44202023	9a		
3AE5 182-1...	800	310	210	■	3	16	50	17.9	40/42	▲	75	28	3	93	245	93	129	51.5/1.5	A7E44202024	6		
3AE5 182-2...	1250	310	210	■	3	16	50	17.9	40/42	▲	75	28	3	93	245	93	129	51.5/1.5	A7E44202024	6		
3AE5 182-3...	1600	310	210	■	3	16	50	17.9	40/42	20	75	28	2.5	90	255	98	122	62.5/102.5	A7E44202024	6a		

▲ On request

■ Standard information on rating plate

1) The mass of the fixed-mounted circuit breaker, fitted on the withdrawable part, increases by the values specified in the dimension drawing of the withdrawable part (page 83)

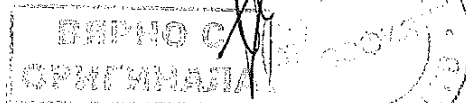

Technical data

SION Vacuum Circuit Breakers 3AE5 and 3AE1

Electrical data, dimensions and masses for 3AE5

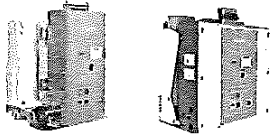

Article No.	12 kV 50/60 Hz		Rated normal current	Width across flats	Pole-center distance	Rated switching sequence: O – 0.3 s – CO – 15 s – CO	Rated short-circuit duration	Rated short-circuit-breaking current	DC component in % of the rated short-circuit-breaking current	Asymmetric breaking current	Rated short-circuit making current (at 50/60 Hz)	Rated back-to-back-capacitor-bank inrush making current	Rated lightning impulse voltage	Rated short-duration power-frequency with- stand voltage	Voltage drop ΔU between connections (acc. to IEC 62271-1 at 100 A DC)	Minimum creepage distance Interruption	Minimum creepage distance Phase-to-earth	Minimum clearance Phase-to-phase	Minimum clearance Phase-to-earth	Mass ¹⁾ (fixed-mounted circuit breaker/withdrawable module)	Detailed dimension drawing (must be explicitly requested)	Operating cycle diagram no. (see page 67)
	I_n A	mm	mm	s	I_{sc} kA	%	kA	I_{mk} kA	I_{bi} kA peak	U_p kV	U_d kV	mV	mm	mm	mm	mm	mm	mm	kg			
3AE5 183-1...	800	310	210	■	3	20	50	22.4	50/52	▲	75	28	3	93	245	93	129	51.5/91.5	A7E44202024	7		
3AE5 183-2...	1250	310	210	■	3	20	50	22.4	50/52	▲	75	28	3	93	245	93	129	51.5/91.5	A7E44202024	7		
3AE5 183-3...	1600	310	210	■	3	20	50	22.4	50/52	20	75	28	2.5	90	255	98	122	62.5/102.5	A7E44202024	7a		
3AE5 183-4...	2000	310	210	■	3	20	50	24.5	50/52	20	75	28	1.8	130	240	125	138	100	A7E10907000	7b		
3AE5 183-6...	2500	310	210	■	3	20	50	24.5	50/52	20	75	28	1.8	130	240	125	138	100	A7E10907000	7b		
3AE5 184-1...	800	310	210	■	3	25	50	28	63/65	▲	75	28	3	93	245	93	129	51.5/91.5	A7E44202024	8a		
3AE5 184-2...	1250	310	210	■	3	25	50	28	63/65	▲	75	28	3	93	245	93	129	51.5/91.5	A7E44202024	8a		
3AE5 184-3...	1600	310	210	■	3	25	50	28	63/65	20	75	28	2.5	90	255	98	122	62.5/102.5	A7E44202024	8b		
3AE5 184-4...	2000	310	210	■	3	25	50	30.6	63/65	20	75	28	1.8	130	240	125	138	100	A7E10907000	8c		
3AE5 184-6...	2500	310	210	■	3	25	50	30.6	63/65	20	75	28	1.8	130	240	125	138	100	A7E10907000	8c		
3AE5 185-1...	800	310	210	■	3	31.5	50	35.4	80/82	20	75	28	2.5	90	255	98	122	56.5/96.5	A7E44202024	9a		
3AE5 185-2...	1250	310	210	■	3	31.5	50	35.4	80/82	20	75	28	2.5	90	255	98	122	56.5/96.5	A7E44202024	9a		
3AE5 185-3...	1600	310	210	■	3	31.5	50	35.4	80/82	20	75	28	2.5	90	255	98	122	62.5/102.5	A7E44202024	9a		
3AE5 185-4...	2000	310	210	■	3	31.5	50	38.6	80/82	20	75	28	1.8	130	240	125	138	100	A7E10907000	9b		
3AE5 185-6...	2500	310	210	■	3	31.5	50	38.6	80/82	20	75	28	1.8	130	240	125	138	100	A7E10907000	9b		
3AE5 554-1...	800	275	160	■	3	25	50	44.9	63/65	▲	75	28	3	93	245	93	129	49/–	A7E44202024	8a		
3AE5 554-2...	1250	275	160	■	3	25	50	44.9	63/65	▲	75	28	3	93	245	93	129	49/–	A7E44202024	8a		
3AE5 555-1...	800	275	160	■	3	31.5	50	35.4	80/82	20	75	28	2.5	90	255	130	135	66.5/–	A7E44202038	9a		
3AE5 555-2...	1250	275	160	■	3	31.5	50	35.4	80/82	20	75	28	2.5	90	255	130	135	66.5/–	A7E44202038	9a		
3AE5 564-3...	1600	275	210	■	3	25	50	28.0	63/65	20	75	28	2.5	90	255	98	122	74.5/–	A7E44202040	8b		
3AE5 565-2...	1250	275	210	■	3	31.5	50	35.4	80/82	20	75	28	2.5	90	255	130	135	69.5/–	A7E44202040	9a		
3AE5 565-3...	1600	275	210	■	3	31.5	50	35.4	80/82	20	75	28	2.5	90	255	130	135	74.5/–	A7E44202040	9a		
3AE5 565-6...	2500	275	210	■	3	31.5	50	38.5	80/82	20	75	28	1.8	130	240	125	138	110	A7E10907005	9b		
3AE5 583-4...	2000	310	275	■	3	20	50	24.5	50/52	20	75	28	1.8	130	240	190	138	105	A7E10907000	7b		
3AE5 583-6...	2500	310	275	■	3	20	50	24.5	50/52	20	75	28	1.8	130	240	190	138	105	A7E10907000	7b		
3AE5 584-4...	2000	310	275	■	3	25	50	30.6	63/65	20	75	28	1.8	130	240	190	138	105	A7E10907000	8c		
3AE5 584-6...	2500	310	275	■	3	25	50	30.6	63/65	20	75	28	1.8	130	240	190	138	105	A7E10907000	8c		
3AE5 585-2...	1250	310	275	■	3	31.5	50	38.6	80/82	20	75	28	2.0	130	240	225	143	105	A7E10907000	9b		
3AE5 585-4...	2000	310	275	■	3	31.5	50	38.6	80/82	20	75	28	1.8	130	240	225	138	105	A7E10907000	9b		
3AE5 585-6...	2500	310	275	■	3	31.5	50	38.6	80/82	20	75	28	1.8	130	240	225	138	105	A7E10907000	9b		

▲ On request

■ Standard information on rating plate

1) The mass of the fixed-mounted circuit breaker, fitted on the withdrawable part, increases by the values specified in the dimension drawing of the withdrawable part (page 83)

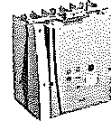

Article No.	12 kV 50/60 Hz		Rated normal current	Width across flats	Pole-center distance	Rated switching sequence: O - 0.3 s - CO - 15 s - CO	Rated short-circuit duration	Rated short-circuit breaking current	DC component in % of the rated short-circuit breaking current	Asymmetric breaking current	Rated short-circuit making current (at 50/60 Hz)	Rated back-to-back-capacitor-bank inrush making current	Rated lightning impulse voltage	Rated short-duration power-frequency with- stand voltage	Voltage drop ΔU between connections (acc. to IEC 62271-1 at 100 A, DC)	Minimum creepage distance Interrupters	Minimum creepage distance Phase-to-earth	Minimum clearance Phase-to-phase	Minimum clearance Phase-to-earth	Mass ¹⁾ (fixed-mounted circuit breaker/withdrawable module)	Detailed dimension drawing (must be explicitly requested)	Operating cycle diagram no. (see page 67)
	I_n	A	mm	mm	s	kA	%	kA	kA	I_{ma}	I_{br} kA peak	U_p	kV	U_d	kV	mV	mm	mm	mm	mm	kg	
3AE1 186-2...	1250	310	210	■	3	40	36	44.9	100/104	10	75	28	1.7	145	155	169	140	120/160	A7E44202070	10		
3AE1 186-4...	2000	310	210	■	3	40	36	44.9	100/104	10	75	28	1.0	145	249	149	140	160/210	A7E44202071	10		
3AE1 186-6...	2500	310	210	■	3	40	36	44.9	100/104	10	75	28	1.0	145	249	149	140	160/210	A7E44202071	10		
3AE1 186-7...	3150	310	210	■	3	40	36	44.9	100/104	10	75	28	1.0	145	249	149	140	160/210	A7E44202071	10		
3AE1 566-2...	1250	275	210	■	3	40	36	44.9	100/104	10	75	28	1.7	145	155	169	140	120/-	-	-	10	
3AE1 566-6...	2500	275	210	■	3	40	36	44.9	100/104	10	75	28	1.0	145	249	149	140	160/-	-	-	10	
3AE1 566-7...	3150	275	210	■	3	40	36	44.9	100/104	10	75	28	1.0	145	249	149	140	160/-	-	-	10	
3AE1 586-2...	1250	310	275	■	3	40	36	44.9	100/104	10	75	28	1.7	145	155	234	140	125/165	A7E44202068	10		
3AE1 586-4...	2000	310	275	■	3	40	36	44.9	100/104	10	75	28	1.0	145	155	214	140	165/205	A7E44202069	10		
3AE1 586-6...	2500	310	275	■	3	40	36	44.9	100/104	10	75	28	1.0	145	155	214	140	165/205	A7E44202069	10		
3AE1 586-7...	3150	310	275	■	3	40	36	44.9	100/104	10	75	28	1.0	145	155	214	140	165/205	A7E44202069	10		

▲ On request

■ Standard information on rating plate

1) The mass of the fixed-mounted circuit breaker, fitted on the withdrawable part, increases by the values specified in the dimension drawing of the withdrawable part (page 83)

3

Handwritten signature

Handwritten signature

ВЕРНО С
ОРИГИНАЛА

Handwritten signature

СЕРТИФИКАТ
11.02.2018

Technical data

SION Vacuum Circuit Breakers 3AE5 and 3AE1

Electrical data, dimensions and masses for 3AE5 and 3AE1



Operating cycle diagrams for 12 kV

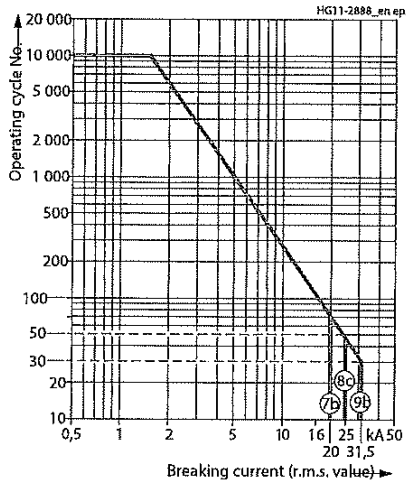
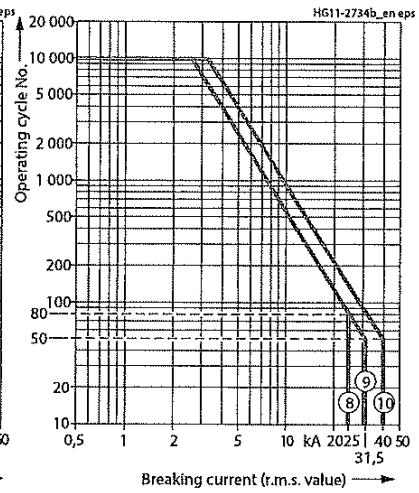
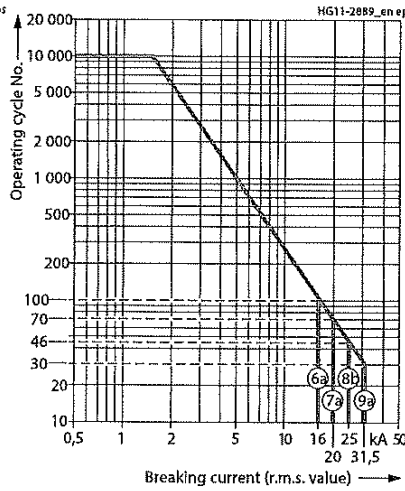
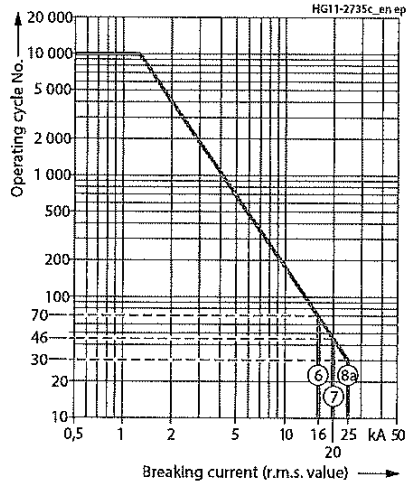

The permissible number of electrical operating cycles is shown as a function of the breaking current (r.m.s. value). All SION vacuum circuit breakers fulfill the endurance classes E2, M2 and C2 according to IEC 62271-100. The curve shape beyond the parameters defined in IEC 62271-100 is based on average usage data. The number of operating cycles that can actually be reached can be different depending on the respective application.

3

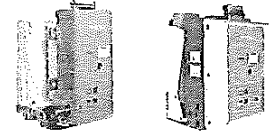

Article No.	17.5 kV 50/60 Hz		Rated normal current I_n A	Width across flats mm	Pole-center distance mm	Rated switching sequence: O - 0.3 s - CO - 15 s - CO	Rated short-circuit duration s	Rated short-circuit breaking current I_{sc} kA	DC component in % of the rated short-circuit breaking current %	Asymmetric breaking current kA	Rated short-circuit making current (at 50/60 Hz) I_{ma} kA	Rated back-to-back-capacitor-bank inrush making current $I_{b, peak}$ kA	Rated lightning impulse voltage U_p kV	Rated short-duration power-frequency with- stand voltage U_d kV	Voltage drop ΔU between connections (acc. to IEC 62271-1) at 100 A DC mV	Minimum creepage distance interrupters mm	Minimum creepage distance Phase-to-earth mm	Minimum clearance Phase-to-phase mm	Minimum clearance Phase-to-earth mm	Mass ¹⁾ (fixed-mounted circuit-breaker/withdrawable module) kg	Detailed dimension drawing (must be explicitly requested)	Operating cycle diagram no. (see page 75)				
	3AE5 202-1...	3AE5 202-2...																					3AE5 204-1...	3AE5 204-2...	3AE5 205-1...	3AE5 205-2...
3AE5 202-1...	800	205	150	■	3	16	50	17.9	40/42	20	95	38	2.5	240	255	130	135	54/-	A7E44202010	12a						
3AE5 202-2...	1250	205	150	■	3	16	50	17.9	40/42	20	95	38	2.5	240	255	130	135	54/-	A7E44202010	12a						
3AE5 204-1...	800	205	150	■	3	25	50	28	63/65	20	95	38	2.5	240	255	130	135	54/-	A7E44202010	13a						
3AE5 204-2...	1250	205	150	■	3	25	50	28	63/65	20	95	38	2.5	240	255	130	135	54/-	A7E44202010	13a						
3AE5 205-1...	800	205	150	■	3	31.5	50	38.6	80/82	20	95	38	2.0	130	240	150	143	83	A7E10907000	14b						
3AE5 205-2...	1250	205	150	■	3	31.5	50	38.6	80/82	20	95	38	2.0	130	240	150	143	83	A7E10907000	14b						
3AE5 212-1...	800	275	150	■	3	16	50	17.9	40/42	20	95	38	2.5	240	255	130	135	54/94	A7E44202011	12a						
3AE5 212-2...	1250	275	150	■	3	16	50	17.9	40/42	20	95	38	2.5	240	255	130	135	54/94	A7E44202011	12a						
3AE5 214-1...	800	275	150	■	3	25	50	28	63/65	20	95	38	2.5	240	255	130	135	54/94	A7E44202011	13a						
3AE5 214-2...	1250	275	150	■	3	25	50	28	63/65	20	95	38	2.5	240	255	130	135	54/94	A7E44202011	13a						
3AE5 215-1...	800	275	150	■	3	31.5	50	38.6	80/82	20	95	38	2.0	130	240	150	143	83	A7E10907000	14b						
3AE5 215-2...	1250	275	150	■	3	31.5	50	38.6	80/82	20	95	38	2.0	130	240	150	143	83	A7E10907000	14b						
3AE5 222-1...	800	310	150	■	3	16	50	17.9	40/42	20	95	38	2.5	240	255	130	135	54/94	A7E44202012	12a						
3AE5 222-2...	1250	310	150	■	3	16	50	17.9	40/42	20	95	38	2.5	240	255	130	135	54/94	A7E44202012	12a						
3AE5 222-3...	1600	310	150	■	3	16	50	17.9	40/42	20	95	38	2.5	240	255	130	135	60/100	A7E44202012	12a						
3AE5 224-1...	800	310	150	■	3	25	50	28	63/65	20	95	38	2.5	240	255	130	135	54/94	A7E44202012	13a						
3AE5 224-2...	1250	310	150	■	3	25	50	28	63/65	20	95	38	2.5	240	255	130	135	54/94	A7E44202012	13a						
3AE5 224-3...	1600	310	150	■	3	25	50	28	63/65	20	95	38	2.5	240	255	130	135	60/100	A7E44202012	13a						
3AE5 225-1...	800	310	150	■	3	31.5	50	38.6	80/82	20	95	38	2.0	130	240	150	143	83	A7E10907000	14b						
3AE5 225-2...	1250	310	150	■	3	31.5	50	38.6	80/82	20	95	38	2.0	130	240	150	143	83	A7E10907000	14b						
3AE5 225-3...	1600	310	150	■	3	31.5	50	38.6	80/82	20	95	38	2.0	130	240	150	143	83	A7E10907000	14b						
3AE5 232-1...	800	205	160	■	3	16	50	17.9	40/42	20	95	38	2.5	240	255	130	135	54/-	A7E44202016	12a						
3AE5 232-2...	1250	205	160	■	3	16	50	17.9	40/42	20	95	38	2.5	240	255	130	135	54/-	A7E44202016	12a						
3AE5 234-1...	800	205	160	■	3	25	50	28	63/65	20	95	38	2.5	240	255	130	135	54/-	A7E44202016	13a						
3AE5 234-2...	1250	205	160	■	3	25	50	28	63/65	20	95	38	2.5	240	255	130	135	54/-	A7E44202016	13a						
3AE5 235-1...	800	205	160	■	3	31.5	50	38.6	80/82	20	95	38	2.0	130	240	160	143	83	A7E10907000	14b						
3AE5 235-2...	1250	205	160	■	3	31.5	50	38.6	80/82	20	95	38	2.0	130	240	160	143	83	A7E10907000	14b						

3

■ Standard information on rating plate

1) The mass of the fixed-mounted circuit breaker, fitted on the withdrawable part, increases by the values specified in the dimension drawing of the withdrawable part (page 83)

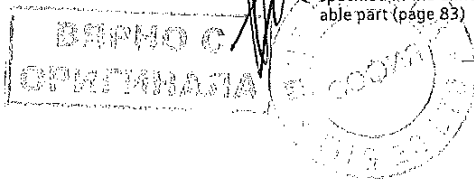

Technical data

SION Vacuum Circuit Breakers 3AE5 and 3AE1

Electrical data, dimensions and masses for 3AE5

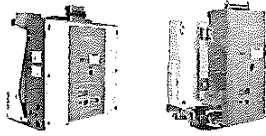

Article No.	17.5 kV 50/60 Hz		Rated normal current I_n A	Width across flats mm	Pole-center distance mm	Rated switching sequence: O - 0.3 s - CO - 15 s - CO	Rated short-circuit duration t_k s	Rated short-circuit breaking current I_{sc} kA	DC component in % of the rated short-circuit breaking current	Asymmetric breaking current kA	Rated short-circuit making current (at 50/60 Hz) I_{ma} kA	Rated back-to-back-capacitor-bank inrush making current I_b kA peak	Rated lightning impulse voltage U_p kV	Rated short-duration power-frequency with- stand voltage U_d kV	Voltage drop ΔU between connections (acc. to IEC 62271-1 at 100 A DC) mV	Minimum creepage distance Interruption mm	Minimum creepage distance Phase-to-earth mm	Minimum clearance Phase-to-phase mm	Minimum clearance Phase-to-earth mm	Mass ¹⁾ (fixed-mounted circuit breaker/withdrawable module) kg	Detailed dimension drawing (must be explicitly requested)	Operating cycle diagram no. (see page 75)
	Rated normal current	Width across flats																				
3AE5 242-1...	800	275	160	■	3	16	50	17.9	40/42	20	95	38	2.5	240	255	130	135	54/-	A7E44202017	12a		
3AE5 242-2...	1250	275	160	■	3	16	50	17.9	40/42	20	95	38	2.5	240	255	130	135	54/-	A7E44202017	12a		
3AE5 244-1...	800	275	160	■	3	25	50	28	63/65	20	95	38	2.5	240	255	130	135	54/-	A7E44202017	13a		
3AE5 244-2...	1250	275	160	■	3	25	50	28	63/65	20	95	38	2.5	240	255	130	135	54/-	A7E44202017	13a		
3AE5 245-1...	800	275	160	■	3	31.5	50	38.6	80/82	20	95	38	2.0	130	240	160	143	83	A7E10907000	14b		
3AE5 245-2...	1250	275	160	■	3	31.5	50	38.6	80/82	20	95	38	2.0	130	240	160	143	83	A7E10907000	14b		
3AE5 252-1...	800	310	160	■	3	16	50	17.9	40/42	20	95	38	2.5	240	255	130	135	54/-	A7E44202018	12a		
3AE5 252-2...	1250	310	160	■	3	16	50	17.9	40/42	20	95	38	2.5	240	255	130	135	54/-	A7E44202018	12a		
3AE5 252-3...	1600	310	160	■	3	16	50	17.9	40/42	20	95	38	2.5	240	255	130	135	60/-	A7E44202018	12a		
3AE5 254-1...	800	310	160	■	3	25	50	28	63/65	20	95	38	2.5	240	255	130	135	54/-	A7E44202018	13a		
3AE5 254-2...	1250	310	160	■	3	25	50	28	63/65	20	95	38	2.5	240	255	130	135	54/-	A7E44202018	13a		
3AE5 254-3...	1600	310	160	■	3	25	50	28	63/65	20	95	38	2.5	240	255	130	135	60/-	A7E44202018	13a		
3AE5 255-1...	800	310	160	■	3	31.5	50	38.6	80/82	20	95	38	2.0	130	240	160	143	83	A7E10907000	14b		
3AE5 255-2...	1250	310	160	■	3	31.5	50	38.6	80/82	20	95	38	2.0	130	240	160	143	83	A7E10907000	14b		
3AE5 255-3...	1600	310	160	■	3	31.5	50	38.5	80/82	20	95	38	2.0	130	240	160	143	83	A7E10907000	14b		
3AE5 262-1...	800	205	210	■	3	16	50	17.9	40/42	20	95	38	2.5	240	255	130	135	57/-	A7E44202022	12a		
3AE5 262-2...	1250	205	210	■	3	16	50	17.9	40/42	20	95	38	2.5	240	255	130	135	57/-	A7E44202022	12a		
3AE5 264-1...	800	205	210	■	3	25	50	28	63/65	20	95	38	2.5	240	255	130	135	57/-	A7E44202022	13a		
3AE5 264-2...	1250	205	210	■	3	25	50	28	63/65	20	95	38	2.5	240	255	130	135	57/-	A7E44202022	13a		
3AE5 265-1...	800	205	210	■	3	31.5	50	38.6	80/82	20	95	38	2.0	130	240	210	143	88	A7E10907000	14b		
3AE5 265-2...	1250	205	210	■	3	31.5	50	38.6	80/82	20	95	38	2.0	130	240	210	143	88	A7E10907000	14b		
3AE5 272-1...	800	275	210	■	3	16	50	17.9	40/42	20	95	38	2.5	240	255	130	135	57/97	A7E44202023	12a		
3AE5 272-2...	1250	275	210	■	3	16	50	17.9	40/42	20	95	38	2.5	240	255	130	135	57/97	A7E44202023	12a		
3AE5 274-1...	800	275	210	■	3	25	50	28	63/65	20	95	38	2.5	240	255	130	135	57/97	A7E44202023	13a		
3AE5 274-2...	1250	275	210	■	3	25	50	28	63/65	20	95	38	2.5	240	255	130	135	57/97	A7E44202023	13a		
3AE5 275-1...	800	275	210	■	3	31.5	50	38.6	80/82	20	95	38	2.0	130	240	210	143	88	A7E10907000	14b		
3AE5 275-2...	1250	275	210	■	3	31.5	50	38.6	80/82	20	95	38	2.0	130	240	210	143	88	A7E10907000	14b		

■ Standard information on rating plate

1) The mass of the fixed-mounted circuit breaker, fitted on the withdrawable part, increases by the values specified in the dimension drawing of the withdrawable part (page 83)

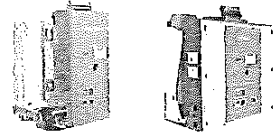

Article No.	17.5 kV and NXAIR 50/60 Hz		Rated normal current	Width across flats	Pole-center distance	Rated switching sequence: O - 0.3 s - CO - 1.5 s - CO	Rated short-circuit duration	Rated short-circuit breaking current	DC component in % of the rated short-circuit breaking current	Asymmetric breaking current	Rated short-circuit making current (at 50/60 Hz)	Rated back-to-back-capacitor-bank inrush making current	Rated lightning impulse voltage	Rated short-duration power-frequency with- stand voltage	Voltage drop ΔU _l between connections (acc. to IEC 62271-1 at 100 A DC)	Minimum creepage distance Interrupters	Minimum creepage distance Phase-to-earth	Minimum clearance Phase-to-phase	Minimum clearance Phase-to-earth	Mass ¹⁾ (fixed-mounted circuit breaker/withdrawable module)	Detailed dimension drawing (must be explicitly requested)	Operating cycle diagram no. (see page 75)
	I_n	A	mm	mm	s	kA	%	kA	kA	kA	kA	kA peak	kV	kV	mV	mm	mm	mm	mm	kg		
3AE5 282-1...	800	310	210	■	3	16	50	17.9	40/42	20	95	38	2.5	240	255	130	135	57/97	A7E44202024	12a		
3AE5 282-2...	1250	310	210	■	3	16	50	17.9	40/42	20	95	38	2.5	240	255	130	135	57/97	A7E44202024	12a		
3AE5 282-3...	1600	310	210	■	3	16	50	17.9	40/42	20	95	38	2.5	240	255	130	135	63/103	A7E44202024	12a		
3AE5 284-1...	800	310	210	■	3	25	50	28	63/65	20	95	38	2.5	240	255	130	135	57/97	A7E44202024	13a		
3AE5 284-2...	1250	310	210	■	3	25	50	28	63/65	20	95	38	2.5	240	255	130	135	57/97	A7E44202024	13a		
3AE5 284-3...	1600	310	210	■	3	25	50	28	63/65	20	95	38	2.5	240	255	130	135	63/103	A7E44202024	13a		
3AE5 284-4...	2000	310	210	■	3	25	50	30.6	63/65	20	95	38	1.8	130	240	196	138	100	A7E10907000	13b		
3AE5 284-6...	2500	310	210	■	3	25	50	30.6	63/65	20	95	38	1.8	130	240	196	138	100	A7E10907000	13b		
3AE5 285-1...	800	310	210	■	3	31.5	50	38.6	80/82	20	95	38	2.0	130	240	210	143	88	A7E10907000	14b		
3AE5 285-2...	1250	310	210	■	3	31.5	50	38.6	80/82	20	95	38	2.0	130	240	210	143	88	A7E10907000	14b		
3AE5 285-3...	1600	310	210	■	3	31.5	50	38.6	80/82	20	95	38	2.0	130	240	210	143	88	A7E10907000	14b		
3AE5 285-4...	2000	310	210	■	3	31.5	50	38.6	80/82	20	95	38	1.8	130	240	196	138	105	A7E10907000	14a		
3AE5 285-6...	2500	310	210	■	3	31.5	50	38.6	80/82	20	95	38	1.8	130	240	196	138	105	A7E10907000	14a		
3AE5 624-1...	800	275	160	■	3	25	50	28	63/65	20	95	38	2.5	240	255	130	135	67/-	A7E44202038	13a		
3AE5 624-2...	1250	275	160	■	3	25	50	28	63/65	20	95	38	2.5	240	255	130	135	67/-	A7E44202038	13a		
3AE5 625-1...	800	275	160	■	3	31.5	50	35.4	80/82	20	95	38	2	130	240	160	143	85	A7E10907005	14b		
3AE5 625-2...	1250	275	160	■	3	31.5	50	35.4	80/82	20	95	38	2	130	240	160	143	85	A7E10907005	14b		
3AE5 654-4...	2000	310	275	■	3	25	50	30.6	63/65	20	95	38	1.8	130	240	261	138	105	A7E10907000	13b		
3AE5 654-6...	2500	310	275	■	3	25	50	30.6	63/665	20	95	38	1.8	130	240	261	138	105	A7E10907000	13b		
3AE5 655-2...	1250	310	275	■	3	31.5	50	38.6	80/82	20	95	38	2.0	130	240	275	143	96	A7E10907000	14b		
3AE5 655-3...	1600	310	275	■	3	31.5	50	38.6	80/82	20	95	38	2.0	130	240	275	143	96	A7E10907000	14b		
3AE5 655-4...	2000	310	275	■	3	31.5	50	38.6	80/82	20	95	38	1.8	130	240	261	138	105	A7E10907000	14a		
3AE5 655-6...	2500	310	275	■	3	31.5	50	38.6	80/82	20	95	38	1.8	130	240	261	138	108	A7E10907000	14a		
3AE5 664-2...	1250	275	210	■	3	25	50	28	63/65	20	95	38	2.5	240	255	130	135	70/-	A7E44202040	13a		
3AE5 664-3...	1600	275	210	■	3	25	50	28	63/65	20	95	38	2.5	240	255	130	135	75/-	A7E44202040	13a		
3AE5 665-2...	1250	275	210	■	3	31.5	50	35.4	80/82	20	95	38	2	130	240	196	143	91	A7E10907005	14b		
3AE5 665-3...	1600	275	210	■	3	31.5	50	35.4	80/82	20	95	38	2	130	240	196	138	84	A7E10907005	14b		
3AE5 665-6...	2500	275	210	■	3	31.5	50	38.5	80/82	20	95	38	1.8	130	240	196	138	110	A7E10907005	14a		

■ Standard information on rating plate

¹⁾ The mass of the fixed-mounted circuit breaker, fitted on the withdrawable part, increases by the values specified in the dimension drawing of the withdrawable part (page 83)

ЗАРНО С
ЛОПНИНА

Technical data

SION Vacuum Circuit Breakers 3AE5 and 3AE1

Electrical data, dimensions and masses for 3AE1

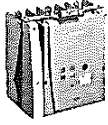

Article No.	17.5 kV 50/60 Hz		Rated normal current	Width across flats	Pole-center distance	Rated switching sequence: O - 0.3 s - CO - 15 s - CO	Rated short-circuit duration	Rated short-circuit breaking current	DC component in % of the rated short-circuit breaking current	Asymmetric breaking current	Rated short-circuit making current (at 50/60 Hz)	Rated back-to-back-capacitor-bank inrush-making current	Rated lightning impulse voltage	Rated short-duration power-frequency with- stand voltage	Voltage drop ΔU between connections (acc. to IEC 62271-1 at 100 A DC)	Minimum creepage distance Interrupters	Minimum creepage distance Phase-to-earth	Minimum clearance Phase-to-phase	Minimum clearance Phase-to-earth	Mass 1) (fixed-mounted circuit breaker/withdrawable module)	Detailed dimension drawing (must be explicitly requested)	Operating cycle diagram no. (see page 75)
	I_n	A	mm	mm	s	kA	%	kA	kA	I_{ms}	$I_{b, peak}$	U_p	U_d	mV	mm	mm	mm	mm	kg			
3AE1 286-2...	1250	310	210	■	3	40	36	44.9	100/104	10	95	38	1.7	145	249	169	140	120/160	A7E44202070	15		
3AE1 286-4...	2000	310	210	■	3	40	36	44.9	100/104	10	95	38	1.0	145	249	149	140	160/210	A7E44202071	15		
3AE1 286-6...	2500	310	210	■	3	40	36	44.9	100/104	10	95	38	1.0	145	249	149	140	160/210	A7E44202071	15		
3AE1 286-7...	3150	310	210	■	3	40	36	44.9	100/104	10	95	38	1.0	145	249	149	140	160/210	A7E44202071	15		
3AE1 666-2...	1250	275	210	■	3	40	36	44.9	100/104	10	95	38	1.7	145	249	169	140	120/-	-	15		
3AE1 666-6...	2500	275	210	■	3	40	36	44.9	100/104	10	95	38	1.0	145	249	149	140	160/-	-	15		
3AE1 666-7...	3150	275	210	■	3	40	36	44.9	100/104	10	95	38	1.0	145	249	149	140	160/-	-	15		
3AE1 656-2...	1250	310	275	■	3	40	36	44.9	100/104	10	95	38	1.7	145	155	234	140	125/165	A7E44202068	15		
3AE1 656-4...	2000	310	275	■	3	40	36	44.9	100/104	10	95	38	1.0	145	155	214	140	165/205	A7E44202069	15		
3AE1 656-6...	2500	310	275	■	3	40	36	44.9	100/104	10	95	38	1.0	145	155	214	140	165/205	A7E44202069	15		
3AE1 656-7...	3150	310	275	■	3	40	36	44.9	100/104	10	95	38	1.0	145	155	214	140	165/205	A7E44202069	15		

■ Standard information on rating plate

1) The mass of the fixed-mounted circuit breaker, fitted on the withdrawable part, increases by the values specified in the dimension drawing of the withdrawable part (page 83)

3

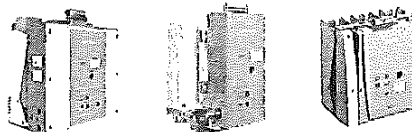

Operating cycle diagrams for 17.5 kV

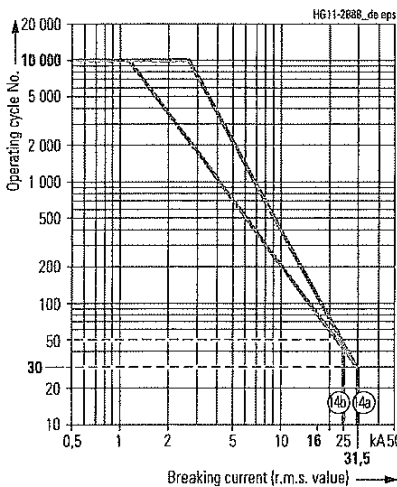
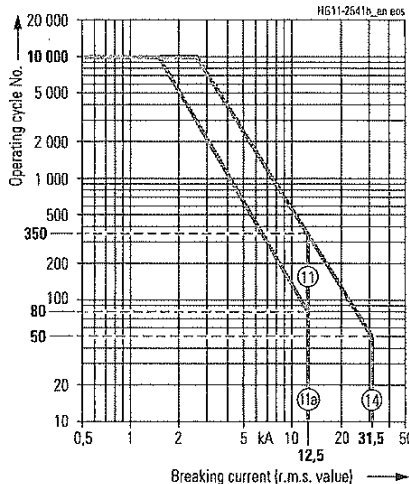
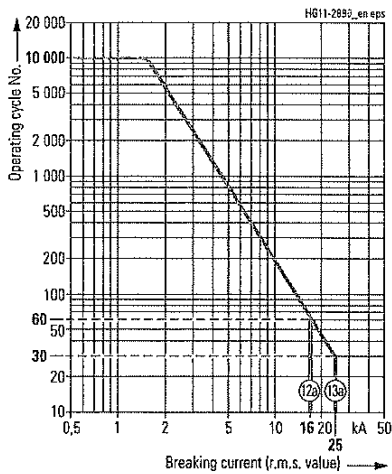
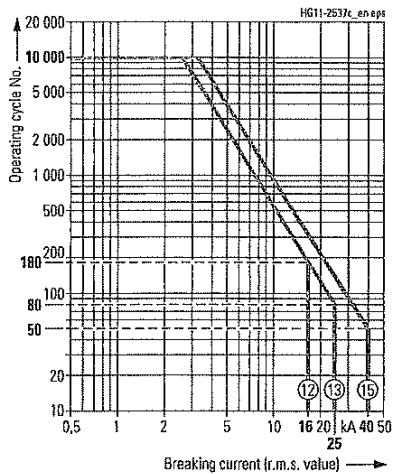

The permissible number of electrical operating cycles is shown as a function of the breaking current (r.m.s. value). All SION vacuum circuit breakers fulfill the endurance classes E2, M2 and C2 according to IEC 62271-100. The curve shape beyond the parameters defined in IEC 62271-100 is based on average usage data. The number of operating cycles that can actually be reached can be different depending on the respective application.

3

Handwritten signature

Handwritten signature

ВЕРНО
ОПРЕДЕЛЕНА

Handwritten signature

Siemens HG 11.02 2018 63

000042

Technical data

Electrical data, dimensions and masses for 3AE5

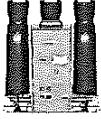

Article No.	24 kV 50/60 Hz			Rated normal current I_n A	Width across flats mm	Pole-center distance mm	Rated switching sequence: O – 0.3 s – CO – 15 s – CO	Rated short-circuit duration t_k s	Rated short-circuit breaking current I_{sc} kA	DC component in % of the rated short-circuit breaking current	Asymmetric breaking current kA	Rated short-circuit making current (at 50/60 Hz) I_{ma} kA	Rated back-to-back-capacitor-bank inrush making current I_b kA peak	Rated lightning impulse voltage U_p kV	Rated short-duration power-frequency with- stand voltage U_d kV	Voltage drop ΔU between connections (acc. to IEC 62271-1) at 100 A DC mV	Minimum creepage distance interrupters mm	Minimum creepage distance Phase-to-earth mm	Minimum clearance Phase-to-phase mm	Minimum clearance Phase-to-earth mm	Mass 1) (fixed-mounted circuit breaker/withdrawable module) kg	Detailed dimension drawing (must be explicitly requested)	Operating cycle diagram no. (see page 76)
	Rated normal current	Width across flats	Pole-center distance																				
3AE5 321-1...	800	310	210	■	3	12.5	50	14.9	31/33	▲	125	50	3	240	250	180	185	65/105	A7E10950000	16a			
3AE5 321-2...	1250	310	210	■	3	12.5	50	14.9	31/33	▲	125	50	3	240	250	180	185	65/105	A7E10950000	16a			
3AE5 322-1...	800	310	210	■	3	16	50	17.9	40/42	▲	125	50	3	240	250	180	185	65/105	A7E10950000	17a			
3AE5 322-2...	1250	310	210	■	3	16	50	17.9	40/42	▲	125	50	3	240	250	180	185	65/105	A7E10950000	17a			
3AE5 323-1...	800	310	210	■	3	20	50	22.4	50/52	▲	125	50	3	240	250	180	185	65/105	A7E10950000	18a			
3AE5 323-2...	1250	310	210	■	3	20	50	22.4	50/52	▲	125	50	3	240	250	180	185	65/105	A7E10950000	18a			
3AE5 324-1...	800	310	210	■	3	25	50	28	63/65	▲	125	50	3	240	250	180	185	65/105	A7E10950000	19a			
3AE5 324-2...	1250	310	210	■	3	25	50	28	63/65	▲	125	50	3	240	250	180	185	65/105	A7E10950000	19a			
3AE5 352-1...	800	310	275	■	3	16	50	17.9	40/42	▲	125	50	3	240	250	180	185	68/108	A7E10950000	17a			
3AE5 352-2...	1250	310	275	■	3	16	50	17.9	40/42	▲	125	50	3	240	250	245	185	68/108	A7E10950000	17a			
3AE5 353-1...	800	310	275	■	3	20	50	22.4	50/52	▲	125	50	3	240	250	245	185	68/108	A7E10950000	18a			
3AE5 353-2...	1250	310	275	■	3	20	50	22.4	50/52	▲	125	50	3	240	250	245	185	68/108	A7E10950000	18a			
3AE5 354-1...	800	310	275	■	3	25	50	28	63/65	▲	125	50	3	240	250	245	185	68/108	A7E10950000	19a			
3AE5 354-2...	1250	310	275	■	3	25	50	28	63/65	▲	125	50	3	240	250	245	185	68/108	A7E10950000	19a			
3AE5 714-1...	800	310	210	■	3	25	50	28	63/65	▲	125	50	3	240	250	180	185	65/105	A7E10950000	19a			
3AE5 714-0...	1000	310	210	■	3	25	50	28	63/65	▲	125	50	3	240	250	180	185	65/105	A7E10950000	19a			
3AE5 714-2...	1250	310	210	■	3	25	50	28	63/65	▲	125	50	3	240	250	180	185	65/105	A7E10950000	19a			

▲ On request

■ Standard information on rating plate

1) The mass of the fixed-mounted circuit breaker, fitted on the withdrawable part, increases by the values specified in the dimension drawing of the withdrawable part (page 83)

3

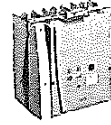

Article No.	24 kV 50/60 Hz		Rated normal current I_n A	Width across flats mm	Pole-center distance mm	Rated switching sequence: O - 0.3 s - CO - 15 s - CO	Rated short-circuit duration t_c s	Rated short-circuit breaking current I_{sc} kA	DC component in % of the rated short-circuit breaking current	Asymmetric breaking current kA	Rated short-circuit making current (at 50/60 Hz) kA	Rated back-to-back-capacitor-bank inrush making current kA peak	Rated lightning impulse voltage kV	Rated short-duration power-frequency with- stand voltage kV	Voltage drop ΔU between connections (acc. to IEC 62271-1 at 100 A DC) mV	Minimum creepage distance interrupters mm	Minimum creepage distance Phase-to-earth mm	Minimum clearance Phase-to-phase mm	Minimum clearance Phase-to-earth mm	Mass ¹⁾ (fixed-mounted circuit breaker/withdrawable module) kg	Detailed dimension drawing (must be explicitly requested)	Operating cycle diagram no. (see page 78)
	Rated normal current	Width across flats																				
3AE1 321-1...	800	310	210	■	3	12.5	36	14.9	31/33	10	125	50	2.6	200	350	200	210	120/160	A7E44202050	16		
3AE1 321-2...	1250	310	210	■	3	12.5	36	14.9	31/33	10	125	50	2.6	200	350	200	210	120/160	A7E44202050	16		
3AE1 322-1...	800	310	210	■	3	16	36	17.9	40/42	10	125	50	2.6	200	350	200	210	120/160	A7E44202050	17		
3AE1 322-2...	1250	310	210	■	3	16	36	17.9	40/42	10	125	50	2.6	200	350	200	210	120/160	A7E44202050	17		
3AE1 322-4...	2000	310	210	■	3	16	36	17.9	40/42	10	125	50	2.0	200	340	200	205	140/180	A7E44202051	17		
3AE1 323-1...	800	310	210	■	3	20	36	22.4	50/52	10	125	50	2.6	200	350	200	210	120/160	A7E44202050	18		
3AE1 323-2...	1250	310	210	■	3	20	36	22.4	50/52	10	125	50	2.6	200	350	200	210	120/160	A7E44202050	18		
3AE1 323-4...	2000	310	210	■	3	20	36	22.4	50/52	10	125	50	2.0	200	340	200	205	140/180	A7E44202051	18		
3AE1 323-6...	2500	310	210	■	3	20	36	22.4	50/52	10	125	50	2.0	200	340	200	205	140/180	A7E44202051	18		
3AE1 324-1...	800	310	210	■	3	25	36	28	63/65	10	125	50	2.6	200	350	200	210	120/160	A7E44202050	19		
3AE1 324-2...	1250	310	210	■	3	25	36	28	63/65	10	125	50	2.6	200	350	200	210	120/160	A7E44202050	19		
3AE1 324-4...	2000	310	210	■	3	25	36	28	63/65	10	125	50	2.0	200	340	200	205	140/180	A7E44202051	19		
3AE1 324-6...	2500	310	210	■	3	25	36	28	63/65	10	125	50	2.0	200	340	200	205	140/180	A7E44202051	19		
3AE1 352-1...	800	310	275	■	3	16	36	17.9	40/42	10	125	50	2.6	200	350	265	210	130/180	A7E44202052	17		
3AE1 352-2...	1250	310	275	■	3	16	36	17.9	40/42	10	125	50	2.6	200	350	265	210	130/180	A7E44202052	17		
3AE1 352-4...	2000	310	275	■	3	16	36	17.9	40/42	10	125	50	2.0	200	340	265	205	150/200	A7E44202053	17		
3AE1 353-1...	800	310	275	■	3	20	36	22.4	50/52	10	125	50	2.6	200	350	265	210	130/180	A7E44202052	18		
3AE1 353-2...	1250	310	275	■	3	20	36	22.4	50/52	10	125	50	2.6	200	350	265	210	130/180	A7E44202052	18		
3AE1 353-4...	2000	310	275	■	3	20	36	22.4	50/52	10	125	50	2.0	200	340	265	205	150/200	A7E44202053	18		
3AE1 353-6...	2500	310	275	■	3	20	36	22.4	50/52	10	125	50	2.0	200	340	265	205	150/200	A7E44202053	18		

■ Standard information on rating plate

1) The mass of the fixed-mounted circuit breaker, fitted on the withdrawable part, increases by the values specified in the dimension drawing of the withdrawable part (page 83)

3

Handwritten signatures and stamps at the bottom of the page, including a circular stamp with text and the number 65.

Technical data

Electrical data, dimensions and masses for 3AE1

SION Vacuum Circuit Breakers 3AE5 and 3AE1

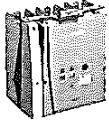

Article No.	24 kV 50/60 Hz		Rated normal current I_n A	Width across flats mm	Pole-center distance mm	Rated switching sequence: O – 0.3 s – CO – 15 s – CO	Rated short-circuit duration t_r s	Rated short-circuit breaking current I_{sc} kA	DC component in % of the rated short-circuit breaking current	Asymmetric breaking current kA	Rated short-circuit making current (at 50/60 Hz) kA	Rated back-to-back-capacitor-bank inrush making current kA peak	Rated lightning impulse voltage kV	Rated short-duration power-frequency with- stand voltage kV	Voltage drop ΔU between connections (acc. to IEC 62271-1 at 100 A DC) mV	Minimum creepage distance interrupters mm	Minimum creepage distance Phase-to-earth mm	Minimum clearance Phase-to-phase mm	Minimum clearance Phase-to-earth mm	Mass ¹⁾ (fixed-mounted circuit breaker/withdrawable module) kg	Detailed dimension drawing (must be explicitly requested)	Operating cycle diagram No. (see below)
	3AE1 354-1...	3AE1 354-2...																				
3AE1 354-1...	800	310	275	■	3	25	36	28	63/65	10	125	50	2.6	200	350	265	210	130/180	A7E44202052	19		
3AE1 354-2...	1250	310	275	■	3	25	36	28	63/65	10	125	50	2.6	200	350	265	210	130/180	A7E44202052	19		
3AE1 354-4...	2000	310	275	■	3	25	36	28	63/65	10	125	50	2.0	200	340	265	205	150/200	A7E44202053	19		
3AE1 354-6...	2500	310	275	■	3	25	36	28	63/65	10	125	50	2.0	200	340	265	205	150/200	A7E44202053	19		
3AE1 714-2...	1250	320	210	■	3	25	36	28	63/65	10	125	50	2.6	200	350	200	210	120/–	–	19		
3AE1 744-4...	2000	320	275	■	3	25	36	28	63/65	10	125	50	2.0	200	340	200	205	150/–	–	19		
3AE1 744-6...	2500	320	275	■	3	25	36	44.9	63/65	10	125	50	2.0	200	340	200	205	150/–	–	19		

■ Standard information on rating plate

1) The mass of the fixed-mounted circuit breaker, fitted on the withdrawable part, increases by the values specified in the dimension drawing of the withdrawable part (page 83)

3

Operating cycle diagrams for 24 kV

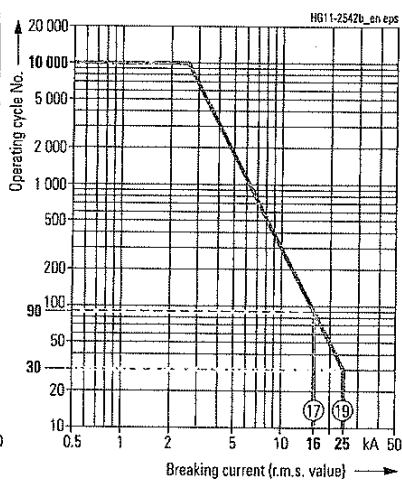
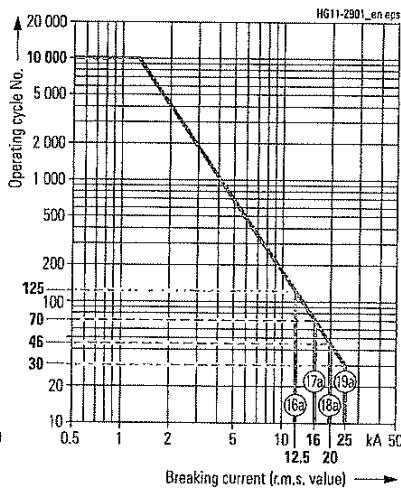
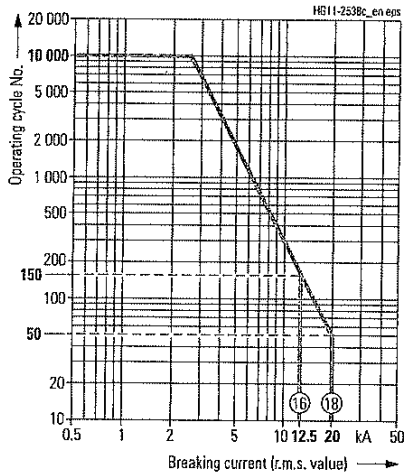

The permissible number of electrical operating cycles is shown as a function of the breaking current (r.m.s. value). All SION vacuum circuit breakers fulfill the endurance classes E2, M2 and C2 according to IEC 62271-100.

The curve shape beyond the parameters defined in IEC 62271-100 is based on average usage data. The number of operating cycles that can actually be reached can be different depending on the respective application.

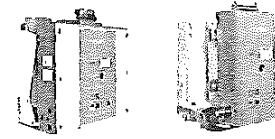

Dimension drawings for 7.2 to 24 kV

Vacuum circuit breaker without contact arm

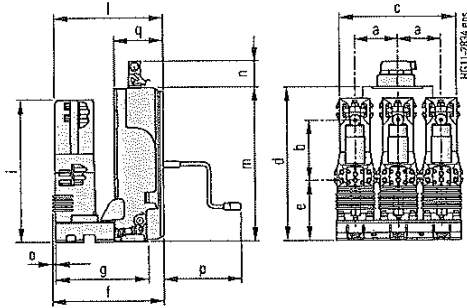

Voltage level	Pole-center distance a mm	Width across flats b mm	c mm	d mm	e mm	f mm	g mm	i mm	l mm	m mm	n mm	o mm	p mm	q mm
7.2 kV	150	205	445	540	217.5	380	329	500.5 ¹⁾²⁾	371	540	105	8	305	169
	150	275	445	540	217.5	380	329	500.5 ¹⁾²⁾	371	540	105	8	305	169
	150	310	445	540	237.5	380	329	500.5 ¹⁾²⁾	371	540	105	8	305	169
	160	205	465	540	217.5	380	329	500.5 ¹⁾²⁾	371	540	105	8	305	169
	160	275	465	540	217.5	380	329	500.5 ¹⁾²⁾	371	540	105	8	305	169
	160	310	465	540	237.5	380	329	500.5 ¹⁾²⁾	371	540	105	8	305	169
	210	205	565	540	217.5	380	329	500.5 ¹⁾	371	540	105	8	305	169
	210	275	565	540	217.5	380	329	500.5 ¹⁾	371	540	105	8	305	169
	210	310	565	540	237.5	380	329	500.5 ¹⁾	371	540	105	8 ³⁾	305	169
12 kV	150	205	445	540	217.5	380	329	500.5 ¹⁾²⁾	371	540	105	8	305	169
	150	275	445	540	217.5	380	329	500.5 ¹⁾²⁾	371	540	105	8	305	169
	150	310	445	540	237.5	380	329	500.5 ¹⁾²⁾	371	540	105	8	305	169
	160	205	465	540	217.5	380	329	500.5 ¹⁾²⁾	371	540	105	8	305	169
	160	275	465	540	217.5	380	329	500.5 ¹⁾²⁾	371	540	105	8	305	169
	160	310	465	540	237.5	380	329	500.5 ¹⁾²⁾	371	540	105	8	305	169
	210	205	565	540	217.5	380	329	500.5 ¹⁾	371	540	105	8	305	169
	210	275	565	540	217.5	380	329	500.5 ¹⁾	371	540	105	8	305	169
	210	310	565	540	237.5	380	329	500.5 ¹⁾	371	540	105	8	305	169
17.5 kV	150	205	445	540	217.5	380	329	540	371	540	105	8	305	169
	150	275	445	540	217.5	380	329	540	371	540	105	8	305	169
	150	310	445	540	237.5	380	329	540	371	540	105	8	305	169
	160	205	465	540	217.5	380	329	540	371	540	105	8	305	169
	160	275	465	540	217.5	380	329	540	371	540	105	8	305	169
	160	310	465	540	237.5	380	329	540	371	540	105	8	305	169
	210	205	565	540	217.5	380	329	540	371	540	105	8	305	169
	210	275	565	540	217.5	380	329	540	371	540	105	8	305	169
	210	310	565	540	237.5	380	329	540	371	540	105	8	305	169
24 kV	210	310	570	540	283	459	399	667	421	540	105	7	305	169
	275	310	695	540	283	459	399	667	421	540	105	7	305	169

3

Note: Small deviations of the dimensions are permissible

- 1) At $I_{sc} = 31.5$ kA or at $I_n = 1600$ A \rightarrow 540 mm
- 2) At $I_{sc} = 31.5$ kA \rightarrow 552 mm
- 3) At $I_n > 1600$ A \rightarrow 30 mm



Technical data

SION Vacuum Circuit Breakers 3AE5 and 3AE1

Dimension drawings for voltage levels 7.2 kV to 24 kV for 3AE1

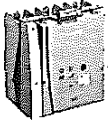

Dimension drawings for 7.2 to 24 kV

Vacuum circuit breaker without contact arm

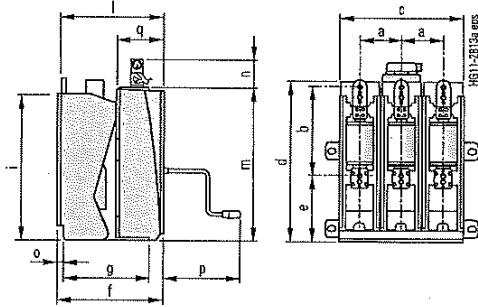

Voltage level	Pole-center distance a mm	Width across flats b mm	c mm	d mm	e mm	f mm	g mm	h mm	i mm	j mm	k mm	l mm	m mm	n mm	o mm	p mm	q mm
7.2 kV	210	310	565	540 ⁵⁾	237.5	380 ¹⁾	300 ^{2) 6)}	523 ^{3) 7)}	371 ⁴⁾	540	105	30 ⁸⁾	279	165			
12 kV	210	275	565	540 ⁵⁾	217.5	380	300 ⁶⁾	523 ⁷⁾	371 ⁴⁾	540	105	30 ⁸⁾	279	165			
	210	310	565	540 ⁵⁾	237.5	380 ¹⁾	300 ^{2) 6)}	523 ^{3) 7)}	371 ⁴⁾	540	105	30 ⁸⁾	279	165			
17.5 kV	210	275	565	562	217.5	380	310	517.5	371 ⁴⁾	540	105	30 ⁸⁾	279	165			
	210	310	565	562	237.5	380 ¹⁾	310 ²⁾	517.5 ³⁾	371 ⁴⁾	540	105	30 ⁸⁾	279	165			
24 kV	210	310	570	739	283	469	360	739	421	540	105	58	279	165			
	275	310	700	739	283	469	360	739	421	540	105	58	279	165			

Note: Small deviations of the dimensions are permissible

- 1) At $I_{sc} = 40 \text{ kA} \rightarrow 450 \text{ mm}$
- 2) At $I_{sc} = 40 \text{ kA} \rightarrow 350 \text{ mm}$
- 3) At $I_{sc} = 40 \text{ kA} \rightarrow 610 \text{ mm}$
- 4) At $I_{sc} = 40 \text{ kA} \rightarrow 420 \text{ mm}$
- 5) At $I_n > 1250 \text{ A}$ or at $I_{sc} = 31.5 \text{ kA} \rightarrow 562 \text{ mm}$
- 6) At $I_n > 1250 \text{ A}$ or at $I_{sc} = 31.5 \text{ kA} \rightarrow 310 \text{ mm}$
- 7) At $I_n > 1250 \text{ A}$ or at $I_{sc} = 31.5 \text{ kA} \rightarrow 518 \text{ mm}$
- 8) At $I_{sc} = 40 \text{ kA} \rightarrow 50 \text{ mm}$

3

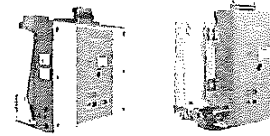

Dimension drawings for 7.2 to 24 kV

Vacuum circuit breaker with contact arm

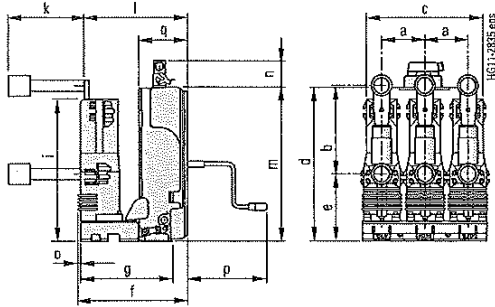

Voltage level	Pole-center distance a mm	Width across flats b mm	c mm	d mm	e mm	f mm	g mm	l mm	k mm	l mm	m mm	n mm	o mm	p mm	q mm
7.2 kV	150	205	445	540	217.5	380	329	500.5 ¹⁾²⁾	274	371	540	105	8	305	169
	150	275	445	540	217.5	380	329	500.5 ¹⁾²⁾	274	371	540	105	8	305	169
	150	310	445	540	237.5	380	329	500.5 ¹⁾²⁾	274	371	540	105	8	305	169
	160	205	465	540	217.5	380	329	500.5 ¹⁾²⁾	274	371	540	105	8	305	169
	160	275	465	540	217.5	380	329	500.5 ¹⁾²⁾	274	371	540	105	8	305	169
	160	310	465	540	237.5	380	329	500.5 ¹⁾²⁾	274	371	540	105	8	305	169
	210	205	565	540	217.5	380	329	500.5 ¹⁾	274	371	540	105	8	305	169
	210	275	565	540	217.5	380	329	500.5 ¹⁾	274	371	540	105	8	305	169
	210	310	565	540	237.5	380	329	500.5 ¹⁾	274	371	540	105	8 ³⁾	305	169
12 kV	150	205	445	540	217.5	380	329	500.5 ¹⁾²⁾	274	371	540	105	8	305	169
	150	275	445	540	217.5	380	329	500.5 ¹⁾²⁾	274	371	540	105	8	305	169
	150	310	445	540	237.5	380	329	500.5 ¹⁾²⁾	274	371	540	105	8	305	169
	160	205	465	540	217.5	380	329	500.5 ¹⁾²⁾	274	371	540	105	8	305	169
	160	275	465	540	217.5	380	329	500.5 ¹⁾²⁾	274	371	540	105	8	305	169
	160	310	465	540	237.5	380	329	500.5 ¹⁾²⁾	274	371	540	105	8	305	169
	210	205	565	540	217.5	380	329	500.5 ¹⁾	274	371	540	105	8	305	169
	210	275	565	540	217.5	380	329	500.5 ¹⁾	274	371	540	105	8	305	169
	210	310	565	540	237.5	380	329	500.5 ¹⁾	274	371	540	105	8	305	169
17.5 kV	275	310	695	540	237.5	380	329	500.5 ¹⁾	274	371	540	105	30	305	169
	150	205	445	540	217.5	380	329	540	274	371	540	105	8	305	169
	150	275	445	540	217.5	380	329	540	274	371	540	105	8	305	169
	150	310	445	540	237.5	380	329	540	274	371	540	105	8	305	169
	160	205	465	540	217.5	380	329	540	274	371	540	105	8	305	169
	160	275	465	540	217.5	380	329	540	274	371	540	105	8	305	169
	160	310	465	540	237.5	380	329	540	274	371	540	105	8	305	169
	210	205	565	540	217.5	380	329	540	274	371	540	105	8	305	169
	210	275	565	540	217.5	380	329	540	274	371	540	105	8	305	169
24 kV	210	310	565	540	237.5	380	329	540	274	371	540	105	8	305	169
	275	310	695	540	237.5	380	329	540	274	371	540	105	30	305	169
	210	310	570	540	283	459	399	667	325	421	540	105	7	305	169
	275	310	695	540	283	459	399	667	325	421	540	105	7	305	169

3

Note: Small deviations of the dimensions are permissible

- 1) At $I_{sc} = 31.5$ kA or at $I_n = 1600$ A --> 540 mm
- 2) At $I_{sc} = 31.5$ kA --> 552 mm
- 3) At $I_n > 1600$ A --> 30 mm

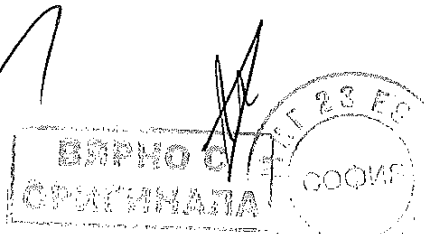

Technical data

Dimension drawings for voltage levels 7.2 kV to 24 kV for 3AE1

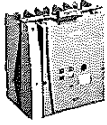

Dimension drawings for 7.2 to 24 kV

Vacuum circuit breaker with contact arm

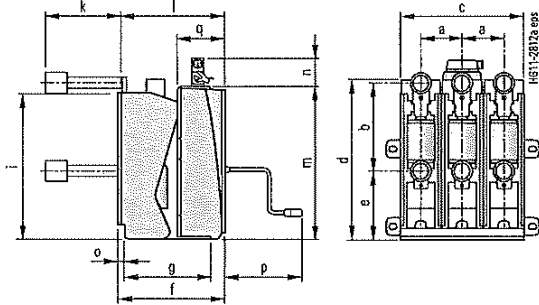

Voltage level	Pole-center distance a mm	Width across flats b mm	c mm	d mm	e mm	f mm	g mm	i mm	k mm	l mm	m mm	n mm	o mm	p mm	q mm
7.2 kV	210	310	565	540 ⁵⁾	237.5	380 ¹⁾	300 ²⁾ 6)	523 ³⁾ 7)	274	371 ⁴⁾	540	105	30 ⁸⁾	279	165
12 kV	210	275	565	540 ⁵⁾	217.5	380	300 ²⁾ 6)	523 ³⁾ 7)	274	371 ⁴⁾	540	105	30 ⁸⁾	279	165
	210	310	565	540 ⁵⁾	237.5	380 ¹⁾	300 ²⁾ 6)	523 ³⁾ 7)	274	371 ⁴⁾	540	105	30 ⁸⁾	279	165
17.5 kV	210	275	565	562	217.5	380	310	517.5 ³⁾	274	371 ⁴⁾	540	105	30 ⁸⁾	279	165
	210	310	565	562	237.5	380 ¹⁾	310 ²⁾	517.5 ³⁾	274	371 ⁴⁾	540	105	30 ⁸⁾	279	165
24 kV	210	310	570	739	283	469	360	739	324	421	540	105	58	279	165
	275	310	700	739	283	469	360	739	324	421	540	105	58	279	165

Note: Small deviations of the dimensions are permissible

- 1) At $I_{sc} = 40 \text{ kA} \rightarrow 450 \text{ mm}$
- 2) At $I_{sc} = 40 \text{ kA} \rightarrow 350 \text{ mm}$
- 3) At $I_{sc} = 40 \text{ kA} \rightarrow 610 \text{ mm}$
- 4) At $I_{sc} = 40 \text{ kA} \rightarrow 420 \text{ mm}$
- 5) At $I_n > 1250 \text{ A}$ or at $I_{sc} = 31.5 \text{ kA} \rightarrow 562 \text{ mm}$
- 6) At $I_n > 1250 \text{ A}$ or at $I_{sc} = 31.5 \text{ kA} \rightarrow 310 \text{ mm}$
- 7) At $I_n > 1250 \text{ A}$ or at $I_{sc} = 31.5 \text{ kA} \rightarrow 518 \text{ mm}$
- 8) At $I_{sc} = 40 \text{ kA} \rightarrow 50 \text{ mm}$

3

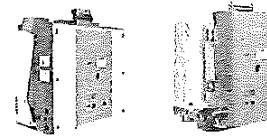

Dimension drawings for 7.2 to 24 kV

Cartridge without earthing switch

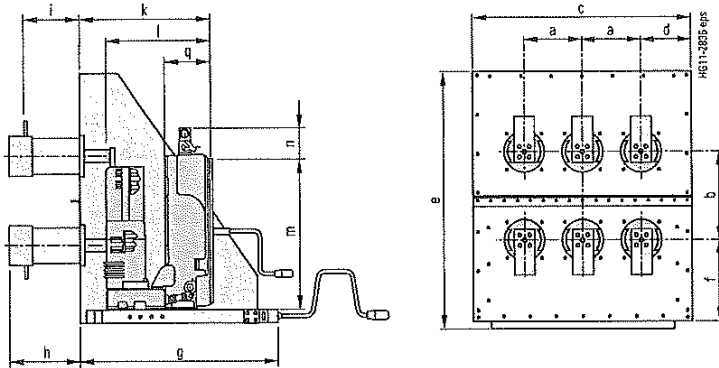

Voltage level	Pole-center distance		Width across flats b mm	c mm	d mm	e mm	f mm	g mm	h mm	i mm	k mm	l mm	m mm	n mm	q mm
	a mm	b mm													
7.2 kV	150	275	275	594	147	850	266.5	710	263	224	476	371	540	105	169
	150	310	310	594	147	905	286.5	710	263	224	476	371	540	105	169
	210	275	275	794	187	850	266.5	710	263	224	476	371	540	105	169
	210	310	310	794	187	905	286.5	710	263	224	476	371	540	105	169
12 kV	150	275	275	594	147	850	266.5	710	263	224	476	371	540	105	169
	150	310	310	594	147	905	286.5	710	263	224	476	371	540	105	169
	210	275	275	794	187	850	266.5	710	263	224	476	371	540	105	169
	210	310	310	794	187	905	286.5	710	263	224	476	371	540	105	169
	275	310	310	994	222	905	286.5	710	263	224	476	371	540	105	169
17.5 kV	150	205	205	594	147	850	266.5	710	263	224	476	371	540	105	169
	150	275	275	594	147	905	286.5	710	263	224	476	371	540	105	169
	210	205	205	794	187	850	266.5	710	263	224	476	371	540	105	169
	210	275	275	794	187	905	286.5	710	263	224	476	371	540	105	169
24 kV	275	310	310	994	222	905	286.5	710	263	224	476	371	540	105	169
	210	310	310	794	187	1040.5	332	810	323	274	537	421	540	105	169
	275	310	310	994	222	1040.5	332	810	323	274	537	421	540	105	169

Note: Small deviations of the dimensions are permissible

Withdrawable part

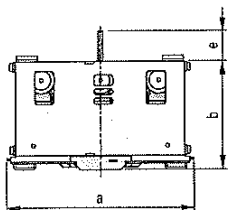
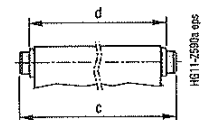

Voltage level	Pole-center distance mm	a mm	b mm	c mm	d mm	e mm	f mm	Mass
7.2 kV	150	529	424	500	470	107	42	approx. 15 kg
	160	529	424	500	470	107	42	approx. 15 kg
	210	679	424	650	620	107	42	approx. 20 kg
12 kV	150	529	424	500	470	107	42	approx. 15 kg
	160	529	424	500	470	107	42	approx. 15 kg
	210	679	424	650	620	107	42	approx. 20 kg
17.5 kV	150	529	424	500	470	107	42	approx. 15 kg
	160	529	424	500	470	107	42	approx. 15 kg
	210	679	424	650	620	107	42	approx. 20 kg
24 kV	210	679	424	650	620	107	42	approx. 20 kg
	275	879	424	850	820	107	42	approx. 25 kg

3

Handwritten signature and scribbles.

ВЕРНО С
ОПРЕДЕЛЕНА

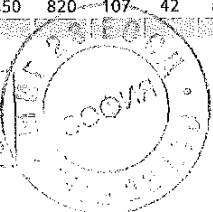

Technical data

SION Vacuum Circuit Breakers 3AE5 and 3AE1

Dimension drawings for voltage levels 7.2 kV to 24 kV for 3AE1

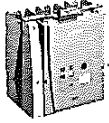

Dimension drawings for 7.2 to 24 kV

Cartridge without earthing switch

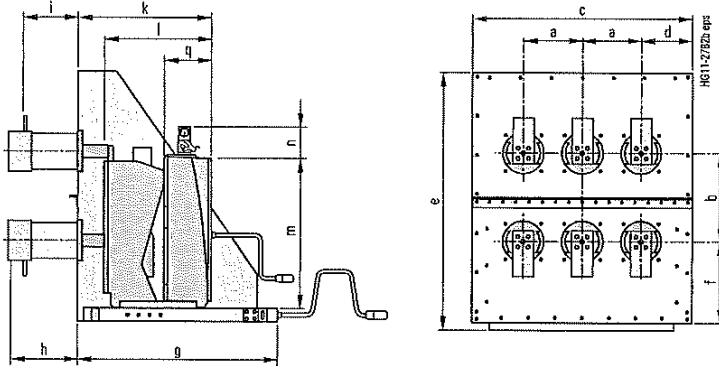

Voltage level	Pole-center distance a mm	Width across flats b mm	c mm	d mm	e mm	f mm	g mm	h mm	h' mm	i mm	i' mm	k mm	l mm	m mm	n mm	q mm
7.2 kV	210	310	794	187	905	286.5	710 ¹⁾	263	323	224	274	476 ²⁾	371 ³⁾	540	105	165
	210	275	794	187	850	286.5	710	263	-	224	-	476	371	540	105	165
12 kV	210	310	794	187	905	286.5	710 ¹⁾	263	323	224	274	476 ²⁾	371 ³⁾	540	105	165
	210	275	794	187	850	286.5	710	263	-	224	-	476	371	540	105	165
17.5 kV	210	310	794	187	905	286.5	710 ¹⁾	263	323	224	274	476 ²⁾	371 ³⁾	540	105	165
	210	275	794	187	850	286.5	710	263	-	224	-	476	371	540	105	165
24 kV	210	310	794	187	1040.5	332	810	323	323	274	323	537	421	540	105	165
	275	310	994	222	1040.5	332	810	323	323	274	323	537	421	540	105	165

h/i = up to $I_n = 1250$ A
 h'/i' = at $I_n = 2000$ A, 2500 A and 3150 A

Note: Small deviations of the dimensions are permissible

- 1) At $I_{sc} = 40$ kA → 760 mm
- 2) At $I_{sc} = 40$ kA → 526 mm
- 3) At $I_{sc} = 40$ kA → 420 mm

3

Withdrawable part

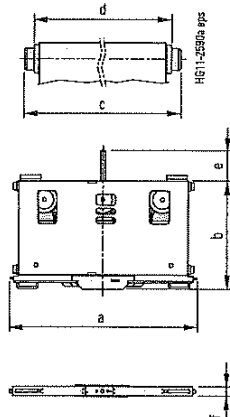

Voltage level	Pole-center distance mm	a mm	b mm	c mm	d mm	e mm	f mm	Mass
7.2 kV	210	679	424	650	620	107	42	approx. 20 kg
12 kV	210	679	424	650	620	107	42	approx. 20 kg
17.5 kV	210	679	424	650	620	107	42	approx. 20 kg
24 kV	210	679	424	650	620	107	42	approx. 20 kg
	275	879	424	850	820	107	42	approx. 25 kg

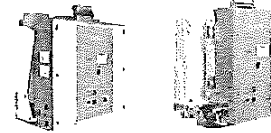

Dimension drawings for 7.2 to 24 kV

Cartridge with earthing switch

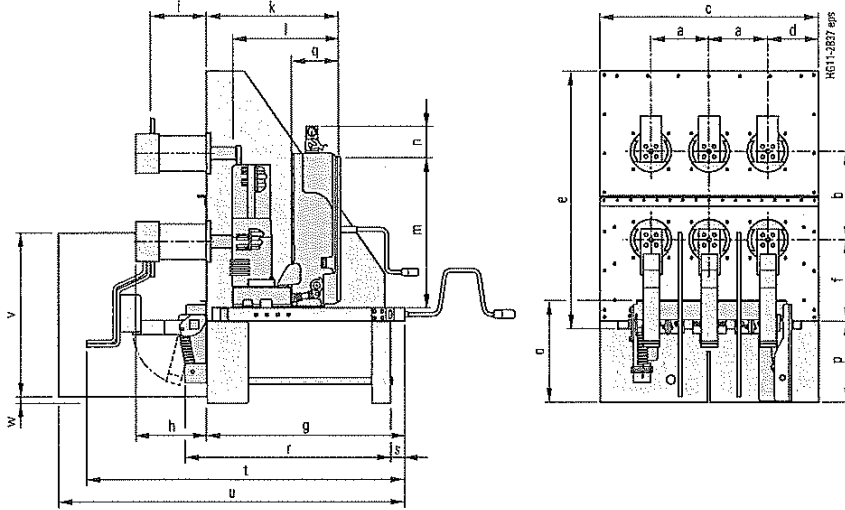

Voltage level	Pole-center distance a mm	Width across flats b mm	c mm	d mm	e mm	f mm	g mm	h mm	j mm	k mm	l mm	m mm	n mm
7.2 kV	150	275	594	147	850	266.5	710	263	224	476	371	540	105
	150	310	594	147	905	286.5	710	263	224	476	371	540	105
	210	275	794	187	850	266.5	710	263	224	476	371	540	105
	210	310	794	187	905	286.5	710	263	224	476	371	540	105
12 kV	150	275	594	147	850	266.5	710	263	224	476	371	540	105
	150	310	594	147	905	286.5	710	263	224	476	371	540	105
	210	275	794	187	850	266.5	710	263	224	476	371	540	105
	210	310	794	187	905	286.5	710	263	224	476	371	540	105
17.5 kV	150	275	594	147	850	266.5	710	263	224	476	371	540	105
	150	310	594	147	905	286.5	710	263	224	476	371	540	105
	210	275	794	187	850	266.5	710	263	224	476	371	540	105
	210	310	794	187	905	286.5	710	263	224	476	371	540	105
24 kV	210	310	794	187	1040.5	332	810	323	274	537	421	540	105
	275	310	994	222	1040.5	332	810	323	274	537	421	540	105

3

Voltage level	o mm	p mm	q mm	r mm	s mm	t mm	u mm	v mm	w mm
7.2 kV	359	287	169	803	64	1142	1233	575	25
	363	287	169	803	64	1142	1233	575	25
	359	287	169	803	65	1143	1234	-	-
	359	287	169	803	65	1142	1234	-	-
12 kV	359	287	169	803	64	1142	1233	575	25
	363	287	169	803	64	1142	1233	575	25
	359	287	169	803	65	1143	1234	-	-
	359	287	169	803	65	1143	1234	-	-
17.5 kV	359	287	169	803	64	1142	1233	575	25
	363	287	169	803	64	1142	1233	575	25
	359	287	169	803	65	1143	1234	-	-
	359	287	169	803	65	1143	1234	-	-
24 kV	359	287	169	902	64	1243	1433	575	10
	359	287	169	902	65	1243	1433	-	-

Note: Small deviations of the dimensions are permissible

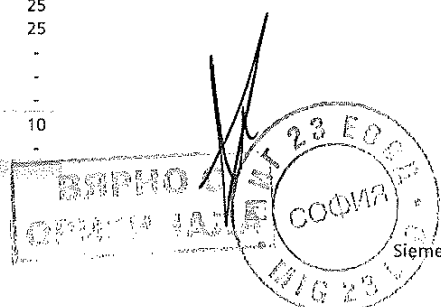

Technical data

SION Vacuum Circuit Breakers 3AE5 and 3AE1

Dimension drawings for voltage levels 7.2 kV to 24 kV for 3AE1

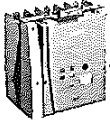

Dimension drawings for 7.2 to 24 kV

Cartridge with earthing switch

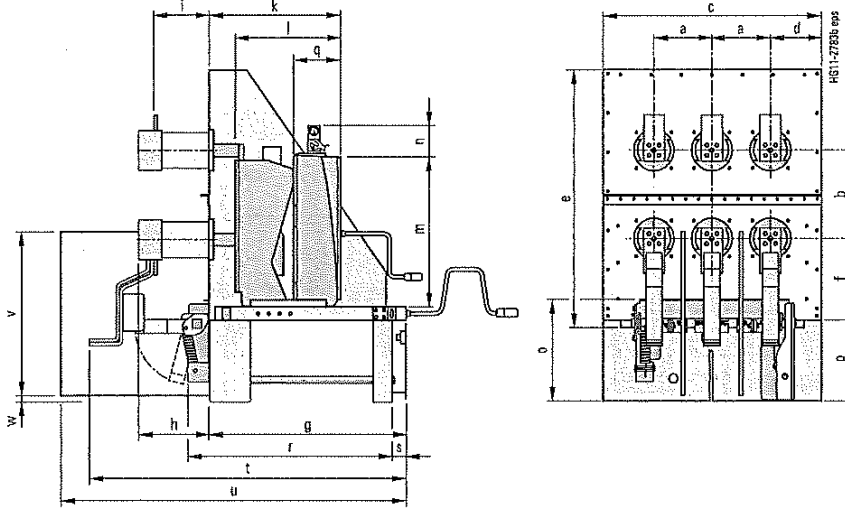

Voltage level	Pole-center distance a mm	Width across flats b mm	c mm	d mm	e mm	f mm	g mm	h mm	h' mm	i mm	i' mm	k mm	l mm	m mm	n mm
7.2 kV	210	310	794	187	905	286.5	710 ¹⁾	263	323	224	274	476 ²⁾	371 ³⁾	540	105
12 kV	210	275	794	187	850	266.5	710 ¹⁾	263	-	224	-	476	371	540	105
	210	310	794	187	905	286.5	710 ¹⁾	263	323	224	274	476 ²⁾	371 ³⁾	540	105
17.5 kV	210	275	794	187	850	266.5	710 ¹⁾	263	-	224	-	476	371	540	105
	210	310	794	187	905	286.5	710 ¹⁾	263	323	224	274	476 ²⁾	371 ³⁾	540	105
24 kV	210	310	794	187	1040.5	332	810	323	323	274	323	537	421	540	105
	275	310	994	222	1040.5	332	810	323	323	274	323	537	421	540	105

3

Voltage level	o mm	p mm	q mm	r mm	s mm	t mm	u mm	v mm	w mm
7.2 kV	359	287	165	803	65	1142	1234	-	-
12 kV	359	287	165	803	65	1143	1234	-	-
	359	287	165	803	65	1143	1234	-	-
17.5 kV	359	287	165	803	65	1143	1234	-	-
	359	287	165	803	65	1143	1234	-	-
24 kV	359	287	165	902	64	1243	1433	575	10
	359	287	165	902	65	1243	1433	-	-

h/i = up to $I_r = 1250$ A
h/i' = at $I_r = 2000$ A, 2500 A and 3150 A

Note: Small deviations of the dimensions are permissible

- 1) At $I_{sc} = 40$ kA -> 760 mm
- 2) At $I_{sc} = 40$ kA -> 526 mm
- 3) At $I_{sc} = 40$ kA -> 420 mm

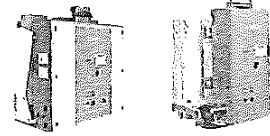

Operating times and internal times for 3AE5

Operating times at rated voltage of the secondary circuit	Equipment of circuit breaker	Circuit breaker operating time
Closing time	–	≤ 60 ms
Opening time	1st shunt release	≤ 30 ms
	2nd and 3rd release	≤ 45 ms
Arcing time	–	< 15 ms
Break time	1st shunt release	≤ 45 ms
	2nd and 3rd release	≤ 60 ms
CLOSE / OPEN contact time	1st shunt release	≤ 60 ms
	2nd and 3rd release	≤ 75 ms
Minimum command duration	Closing solenoid	45 ms
	1st shunt release	40 ms
Pulse time for circuit breaker tripping signal	2nd and 3rd release	20 ms
	1st shunt release	> 10 ms
Charging time for electrical operation	2nd and 3rd release	> 6 ms
	1st shunt release	< 15 s
Synchronism error between the poles	–	≤ 2 ms

Motor short-circuit protection (fuse protection of drive motors) for 3AE5

Rated voltage of the motor V	Operating voltage		Power consumption of the motor W/VA	Smallest possible rated current ¹⁾ of the miniature circuit breaker with C-characteristic A
	max. V	min. V		
24 DC	26	20	140	6
48 DC	53	41	140	3
60 DC	66	51	150	3
110 DC	121	93	280	3
220 DC	242	187	260	1.2
110 AC	121	93	280	3
230 AC	244	187	260	1.2

1) The inrush current in the drive motor can be neglected due to its very short presence.

Consumption data of releases for 3AE5

Release	Power consumption		Tripping ranges	
	Operation at		Tripping voltage at DC	Tripping voltage or tripping current at AC 50/60 Hz
	DC approx. W	AC 50/60 Hz approx. VA		
Closing solenoid 3AY14 10	300 – 370	300 – 370	85 to 110 % U	85 to 110 % U
1st shunt release (without stored-energy mechanism) 3AY14 10	300	300	70 to 110 % U	85 to 110 % U
Undervoltage release 3AX11 03	20	20	35 to 0 % U	35 to 0 % U
Current-transformer-operated release 3AX (rated normal current 0.5 A, 1 A or 5 A)	–	10 ²⁾	–	90 to 110 % I _n
Current-transformer-operated release 3AX11 04 (tripping pulse ≥ 0.1 Ws)	–	–	–	–

2) Consumption at pickup current (90 % of the rated normal current) and open armature.

3

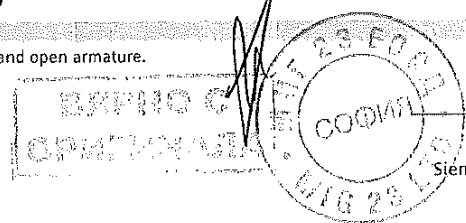

Technical data

SION Vacuum Circuit Breakers 3AE5 and 3AE1

Operating times and internal times, short-circuit protection of motors, consumption data of the releases

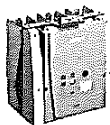

Operating times and internal times for 3AE1

Operating times at rated voltage of the secondary circuit	Equipment of circuit breaker	Circuit breaker operating time
Closing time	–	< 60 ms
Opening time	1st shunt release	< 60 ms
	2nd release	< 45 ms
Arcing time	–	< 15 ms
Break time	1st shunt release	< 75 ms
	2nd release	< 60 ms
CLOSE/OPEN contact time	1st shunt release	< 75 ms
	2nd release	< 60 ms
Minimum command duration	Closing solenoid	45 ms
	1st shunt release	40 ms
	2nd release	20 ms
	1st shunt release	> 15 ms
Pulse time for circuit breaker tripping signal	1st shunt release	> 10 ms
	2nd release	> 10 ms
Charging time for electrical operation	–	< 15 s
Synchronism error between the poles	–	≤ 2 ms

Motor short-circuit protection (fuse protection of drive motors) for 3AE1

Rated voltage of the motor	Operating voltage		Power consumption of the motor	Smallest possible rated current ¹⁾ of the miniature circuit breaker with C-characteristic
	max. V	min. V		
24 DC ²⁾	26	20	520 – 590	8
48 DC	53	41	470 – 600	6
60 DC	66	51	520 – 610	4
110 DC	121	93	650 – 740	4
220 DC	242	187	610 – 900	1.6
110 AC	121	93	670 – 740 VA	2
230 AC	244	187	620 – 960 VA	1.6

1) The inrush current in the drive motor can be neglected due to its very short presence.

2) Does not apply to a rated short-circuit breaking current of 40 kA

Consumption data of releases for 3AE1

Release	Power consumption		Tripping ranges	
	Operation at		Tripping voltage at DC	Tripping voltage or tripping current at AC 50/60 Hz
	DC approx. W	AC 50/60 Hz approx. VA		
Closing solenoid 3AY15 10	140 – 210	140 – 210	85 to 110 % U	85 to 110 % U
1st shunt release (without stored-energy mechanism) 3AY15 10	140	140	70 to 110 % U	85 to 110 % U
2nd shunt release (with stored-energy mechanism) 3AX11 01	70	50	70 to 110 % U	85 to 110 % U
Undervoltage release 3AX11 03	20	20	35 to 0 % U	35 to 0 % U
Current-transformer-operated release 3AX (rated normal current 0.5 A, 1 A or 5 A)	–	10 ²⁾	–	90 to 110 % I _N
Current-transformer-operated release 3AX11 04 (tripping pulse ≥ 0.1 Ws)	–	–	–	–

2) Consumption at pickup current (90 % of the rated normal current) and open armature.

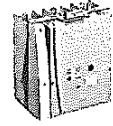

Circuit diagrams for 3AE5 and 3AE1 can be found at the Siemens Industry Online Support (SIOS):

<http://support.industry.siemens.com/>

Circuit manual 3AE5 (64-pole): SA7E449 99009 021

Circuit manual 3AE5 (24-pole): SA7E449 99009 022

Circuit manual 3AE5 (20-pole): SA7E449 99009 013

Circuit manual 3AE1 (64-pole): SA7E449 99007 001

Circuit manual 3AE1 (24-pole): SA7E449 99007 002

Circuit manual 3AE1 (27-pole): SA7E449 99007 003

Handwritten signature

Handwritten signature

БІЛНІО С
ОПНІ МНАГІА

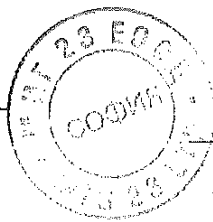

Handwritten signature

3

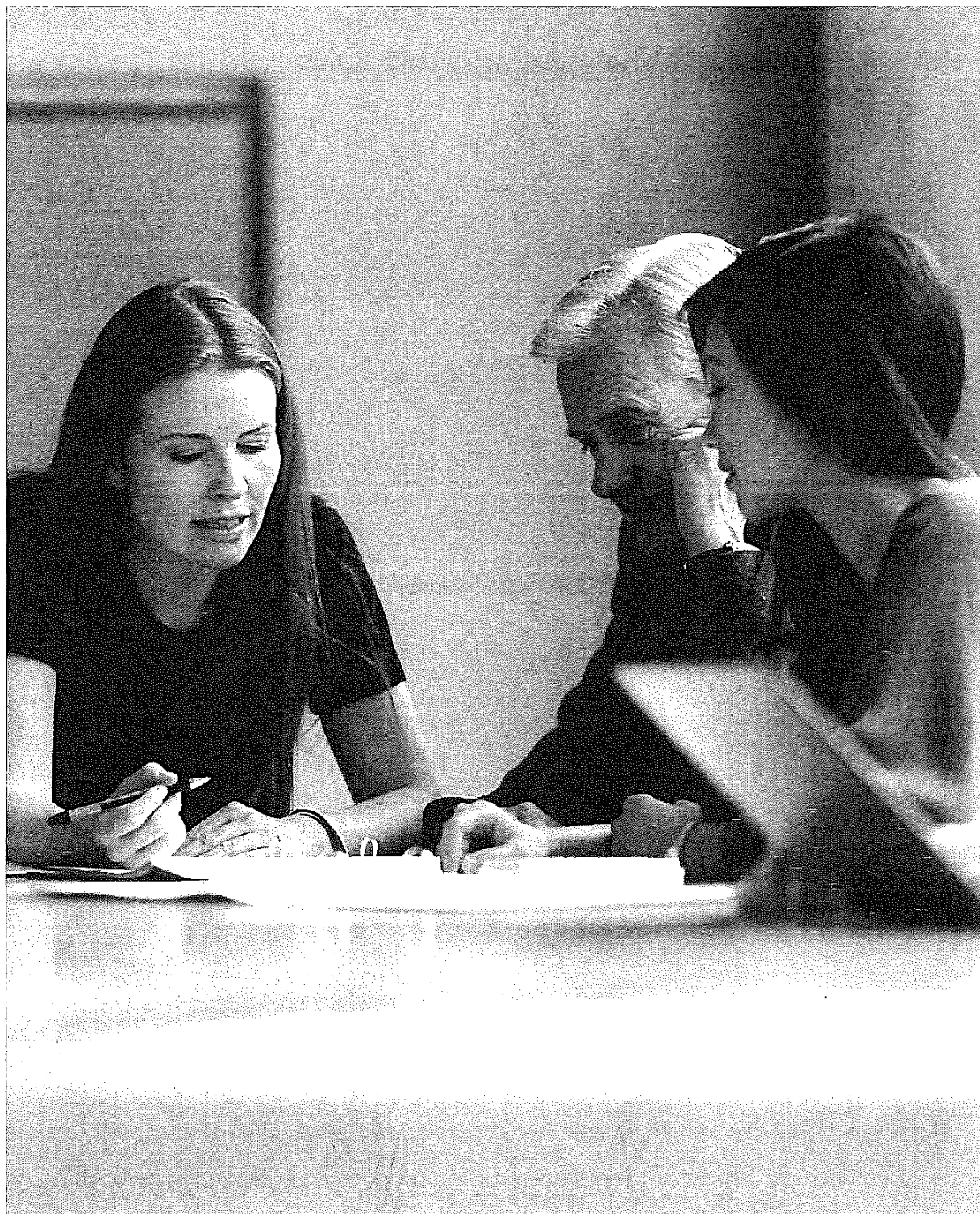



3

Cy

B

СИММЕНС
ОПТИМАЛ

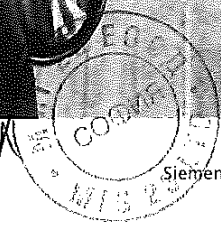

[Handwritten signature]



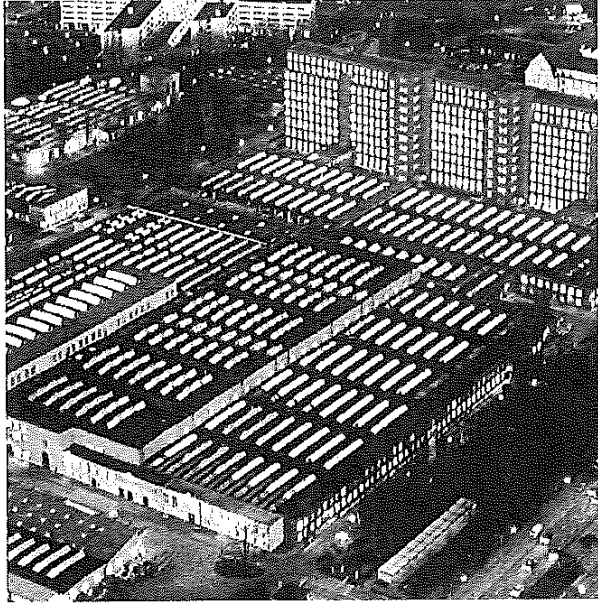

Switchgear Factory in Berlin, Germany

Contents	Page
Annex	79
Inquiry form	80
Configuration instructions	81
Configuration aid	Foldout page

Cm

B

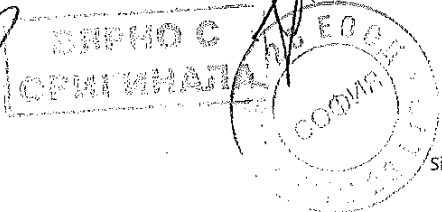

Appendix
Inquiry form

Please copy, fill in and return to your Siemens partner.

Inquiry concerning
SION vacuum
circuit breaker
from 7.2 kV to 24 kV

Please

- Submit an offer
- Call us
- Visit us

Your address

Company

Department

Name

Street

Postal code/ city

Country

Phone

Fax

Email

Siemens AG

Department

Name

Street

Postal code/ city

Country

Fax

Technical data

				Other values
Rated voltage	<input type="checkbox"/> 7.2 kV <input type="checkbox"/> 24 kV	<input type="checkbox"/> 12 kV	<input type="checkbox"/> 17.5 kV	<input type="checkbox"/> ___ kV
Rated lightning impulse withstand voltage	<input type="checkbox"/> 60 kV <input type="checkbox"/> 125 kV	<input type="checkbox"/> 75 kV	<input type="checkbox"/> 95 kV	<input type="checkbox"/> ___ kV
Rated short-duration power-frequency withstand voltage	<input type="checkbox"/> 20 kV <input type="checkbox"/> 42 kV	<input type="checkbox"/> 28 kV <input type="checkbox"/> 50 kV	<input type="checkbox"/> 38 kV <input type="checkbox"/> 55 kV	<input type="checkbox"/> ___ kV
Rated short-circuit breaking current	<input type="checkbox"/> 12.5 kA <input type="checkbox"/> 25 kA	<input type="checkbox"/> 16 kA <input type="checkbox"/> 31.5 kA	<input type="checkbox"/> 20 kA <input type="checkbox"/> 40 kA	<input type="checkbox"/> ___ kA
Rated normal current	<input type="checkbox"/> 800 A <input type="checkbox"/> 2500 A	<input type="checkbox"/> 1250 A <input type="checkbox"/> 3150 A	<input type="checkbox"/> 2000 A	<input type="checkbox"/> ___ A
Pole-center distance	<input type="checkbox"/> 150 mm	<input type="checkbox"/> 160 mm	<input type="checkbox"/> 210 mm	<input type="checkbox"/> 275 mm
Width across flats	<input type="checkbox"/> 205 mm	<input type="checkbox"/> 275 mm	<input type="checkbox"/> 310 mm	

Secondary equipment

For possible combinations, see pages 35 to 40

Circuit breaker installation equipment Fixed mounting

Withdrawable part, contact arms
 Withdrawable part, contact arms, bushings
 Withdrawable module with earthing switch
 Withdrawable module without earthing switch
 Retrofit

Drive motor DC ___ V AC ___ V, ___ Hz

Closing solenoid DC ___ V AC ___ V, ___ Hz

1st shunt release DC ___ V AC ___ V, ___ Hz

2nd shunt release DC ___ V AC ___ V, ___ Hz

C.t.-operated release

Undervoltage release DC ___ V AC ___ V, ___ Hz

Auxiliary switch 6 NO + 6 NC 12 NO + 12 NC

Low-voltage connection 20-pole plug connector or 27-pole terminal strip 24-pole plug 64-pole plug

Mechanical interlocking

Circuit breaker tripping signal

Electrical closing lock-out

Operating instructions German English French Spanish

Application and other requirements

Please check off Please fill in

You prefer to configure your SION vacuum circuit breaker on your own?
Please follow the steps for configuration and enter the article number in the configuration aid.

Instruction for configuration of the SION vacuum circuit breaker

1st step: Definition of the circuit breaker and equipment package (see pages 18 to 34)

Please specify the following ratings:	Possible options:
Rated voltage (U_r)	U_r : 7.2 kV to 24 kV
Rated lightning impulse voltage (U_p)	U_p : 60 kV to 125 kV
Rated short-duration power-frequency withstand voltage (U_d)	U_d : 20 kV, 28 kV, 32 kV, 42 kV, 55 kV, 65 kV
Rated short-circuit breaking current (I_{sc})	I_{sc} : 16 kA to 40 kA
Rated normal current (I_r)	I_r : 800 A to 3150 A
Pole-center distance	150 mm to 275 mm
Width across flats	205 mm to 310 mm

These ratings define the positions 5 to 8 of the article number.

2nd step: Definition of the secondary equipment (see pages 35 to 40)

Please specify the following equipment features:	Possible options:
Release combination (position 9)	Shunt release, current-transformer-operated release and undervoltage release
Closing solenoid (position 10)	Operating voltages from 24 V DC to 240 V AC
Operating voltage of the releases (positions 11/12)	Operating voltages from 24 V DC to 240 V AC
Installation accessories (position 13)	Fixed mounting, with withdrawable part, with contact, fixed contact, bushing, cartridge, with/without earthing switch
Drive motor (position 14)	Operating voltages from 24 V DC to 240 V AC
Number of auxiliary contacts (position 15)	6 NO + 6 NC, 12 NO + 12 NC
Design of the secondary connection (position 15)	20-pole plug connector or 27-pole terminal strip, 24-pole plug, 64-pole plug
Mechanical interlocking, circuit breaker tripping signal (position 15)	With or without
Language of the documentation (position 16)	English, German, French, Spanish, Russian, further languages on request
Frequency of the operating voltage of the secondary equipment at AC (position 16)	DC or AC 50 Hz; 60 Hz

These equipment features define the positions 9 to 16 of the article number.

3rd step: Do you have any further requirements concerning the equipment? (Please refer to page 41)
Your Siemens sales partner will be pleased to support you.

На основании чл.36а ал.3 от
ЗОП

For configuration of your
SION vacuum circuit breaker

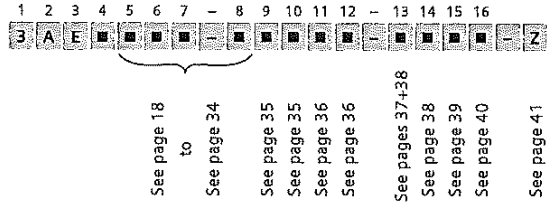

3 A E					
	+		+		+
	+		+		+
3 A E					
	+		+		+
	+		+		+
3 A E					
	+		+		+
	+		+		+
3 A E					
	+		+		+
	+		+		+
3 A E					
	+		+		+
	+		+		+



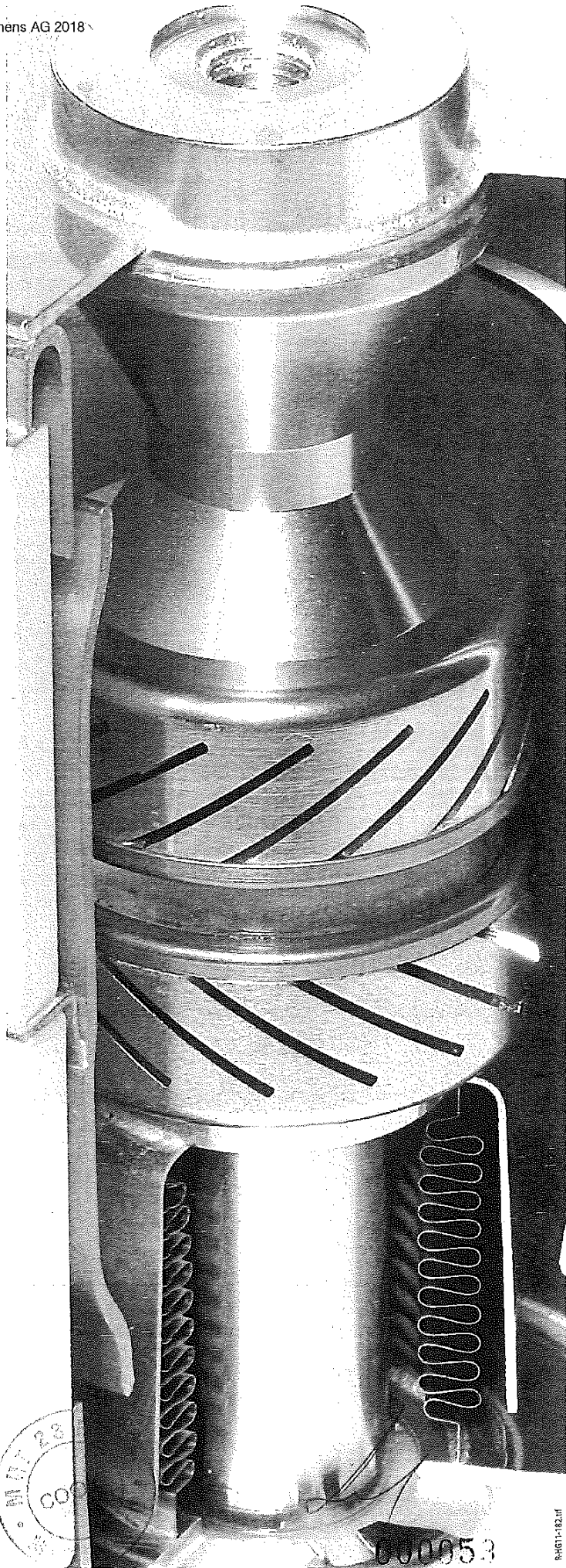

CM

Handwritten signature

ИЗРНО С
ОРИГИНАЛА

МАЈ 28
2018
CO

000053

Get more information

www.siemens.com/lowvoltage

Siemens AG
Energy Management
Low Voltage & Products
Postfach 10 09 53
93009 Regensburg
Germany

© Siemens AG 2018
Subject to change without prior notice
Article No. EMLP-C10162-00-7600
KG 0418 .5 WÜ 82 En / Dispo 18301
Printed in Germany

The information provided in this catalog contains merely general descriptions or characteristics of performance which in case of actual use do not always apply as described or which may change as a result of further development of the products. An obligation to provide the respective characteristics shall only exist if expressly agreed in the terms of contract. Availability and technical specifications are subject to change without notice.

All product designations may be trademarks or product names of Siemens AG or supplier companies whose use by third parties for their own purposes could violate the rights of the owners.

Security information

Siemens provides products and solutions with industrial security functions that support the secure operation of plants, systems, machines and networks.

In order to protect plants, systems, machines and networks against cyber threats, it is necessary to implement – and continuously maintain – a holistic, state-of-the-art industrial security concept. Siemens' products and solutions constitute one element of such a concept.

Customers are responsible for preventing unauthorized access to their plants, systems, machines and networks. Such systems, machines and components should only be connected to an enterprise network or the internet if and to the extent such a connection is necessary and only when appropriate security measures (e.g. firewalls and/or network segmentation) are in place.

For additional information on industrial security measures that may be implemented, please visit <https://www.siemens.com/industrialsecurity>.

Siemens' products and solutions undergo continuous development to make them more secure. Siemens strongly recommends that product updates are applied as soon as they are available and that the latest product versions are used. Use of product versions that are no longer supported, and failure to apply the latest updates may increase customer's exposure to cyber threats.

To stay informed about product updates, subscribe to the Siemens Industrial Security RSS Feed under <https://www.siemens.com/industrialsecurity>.



www.siemens.com/SION

